

DeviceMaster UP

Modbus Solution Examples

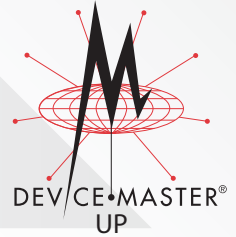

This document includes a number of Modbus connectivity examples which are intended to help the system integrator or plant engineer determine how to set up installations. These examples include information such as the recommended chassis and Modbus firmware for each configuration. Information on how to configure the functionality for each particular DeviceMaster is left to the User Guide Manuals.

Due to flexibility of the DeviceMaster UP Modbus firmware applications, it is not possible to show every possible

Modbus solution. The Modbus Router and Modbus/TCP firmware applications provide the ability to create either very simple or very complex Modbus installations. For instance, you can combine more than one of these connectivity solutions onto one gateway or use several gateways to build a Modbus network. (A Modbus network typically involves multiple gateways providing communication between Modbus controller(s) and device(s) on a network.)

When setting up your Modbus installation, please keep the following in mind:

- When using either Modbus Router or Modbus/TCP firmware, all Modbus masters can communicate to all slave devices. For example, you can have multiple serial and Modbus/TCP masters communicating to the same or different slave(s) at one time.
- When using Modbus/TCP firmware, both Modbus controllers and applications can communicate to a single raw/ASCII device at the same time.
- Modbus messages are automatically converted from one format to another. For instance, you can connect Modbus/RTU masters to Modbus/TCP or Modbus/ASCII slaves and the gateway automatically performs all conversions and message verification.
- Each serial port or Ethernet TCP/IP device interface is individually configurable. That allows:
 - o For Modbus/TCP and Modbus Router firmware, multiple serial master or slave devices of either the same or different Modbus type can be attached to the same gateway.
 - o For Modbus/TCP firmware, each raw/ASCII serial port or Ethernet TCP/IP device interface can operate in different receive and transmit modes. (i.e. One can operate in master mode while others operate in slave or master/slave mode.)

If you have an installation that is not covered by these examples or if you are not certain how to set up your environment, please call the Control customer support staff for more information.

To find the Modbus Solution for your installation, please follow the solution outline:



1. <u>You have a Modbus/TCP Master Controller</u>	3
<u>a. And you have Serial Modbus/RTU Slave(s)</u>	3
<u>b. And you have Serial Modbus/ASCII Slave(s)</u>	3
<u>c. And you have Serial Raw/ASCII Device(s)</u>	4
<u>d. And you have Ethernet Raw/ASCII Device(s)</u>	4
2. <u>You have a Modbus/TCP Slave Controller</u>	5
<u>a. And you have Raw/ASCII Serial Device(s)</u>	5
<u>b. And you have Raw/ASCII Ethernet Device(s)</u>	5
3. <u>You have a Modbus/TCP Master/Slave Controller</u>	6
<u>a. And you have Raw/ASCII Serial Device(s)</u>	6
<u>b. And you have Raw/ASCII Ethernet Device(s)</u>	6
4. <u>You have a Modbus/RTU or Modbus/ASCII Serial Master Controller</u>	7
<u>a. And you have Serial Modbus/RTU Slave(s)</u>	7
<u>b. And you have Serial Modbus/ASCII Slave(s)</u>	7
<u>c. And you have Modbus/TCP Slaves</u>	8
<u>d. And you have Serial Raw/ASCII Device(s)</u>	8
<u>e. And you have Raw/ASCII Ethernet Device(s)</u>	9
<u>f. And you have Remote Serial Modbus/RTU Slave(s)</u>	9
<u>g. And you have Remote Modbus/ASCII Slave(s)</u>	10
<u>h. And you have Remote Raw/ASCII Serial Device(s)</u>	10
5. <u>You have a Modbus/RTU or Modbus/ASCII Serial Slave Controller</u>	11
<u>a. And you have Raw/ASCII Serial Device(s)</u>	11
<u>b. And you have Raw/ASCII Ethernet Device(s)</u>	11
<u>c. And you have Remote Raw/ASCII Serial Device(s)</u>	12
6. <u>You have a Modbus/RTU or Modbus/ASCII over Ethernet TCP/IP Master</u>	13
<u>a. And you have Modbus/RTU Serial Slave(s)</u>	13
<u>b. And you have Modbus/ASCII Serial Slave(s)</u>	13
<u>c. And you have Modbus/TCP Slaves</u>	14
7. <u>You have an Application that Communicates via Raw/ASCII over Ethernet TCP/IP Connection(s)</u>	15
<u>a. And you have Raw/ASCII Serial Device(s)</u>	15
<u>b. And you have Raw/ASCII Ethernet Device(s)</u>	15

1. You have a Modbus/TCP Master Controller

This typically includes such controllers as PLCs, OPC Servers, SCADA Systems, HMIs and applications that communicate as a master via Modbus/TCP.

a. And you have Serial Modbus/RTU Slave(s)

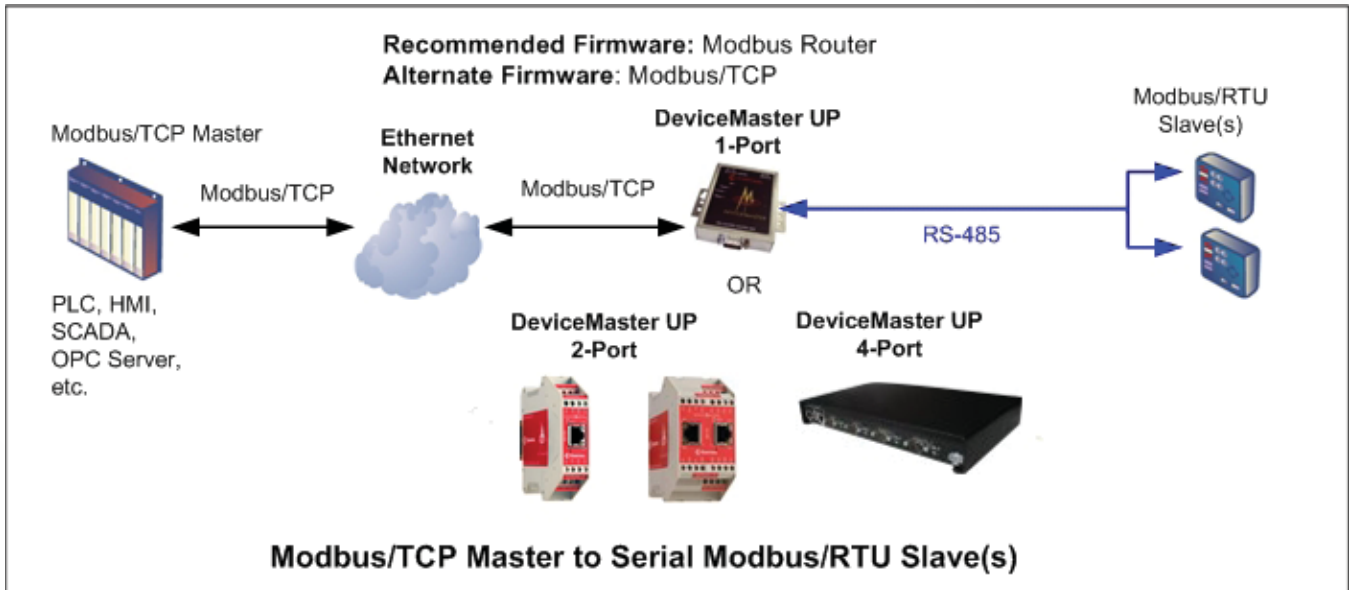

b. And you have Serial Modbus/ASCII Slave(s)

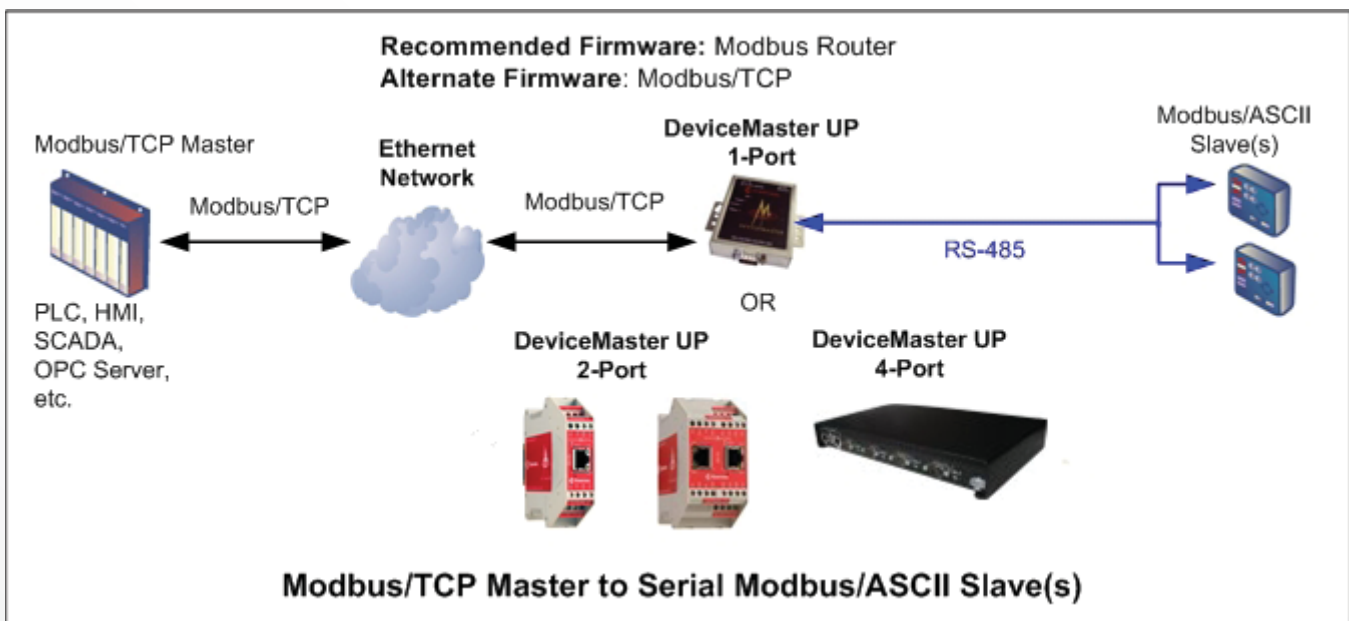

c. And you have Serial Raw/ASCII Device(s)

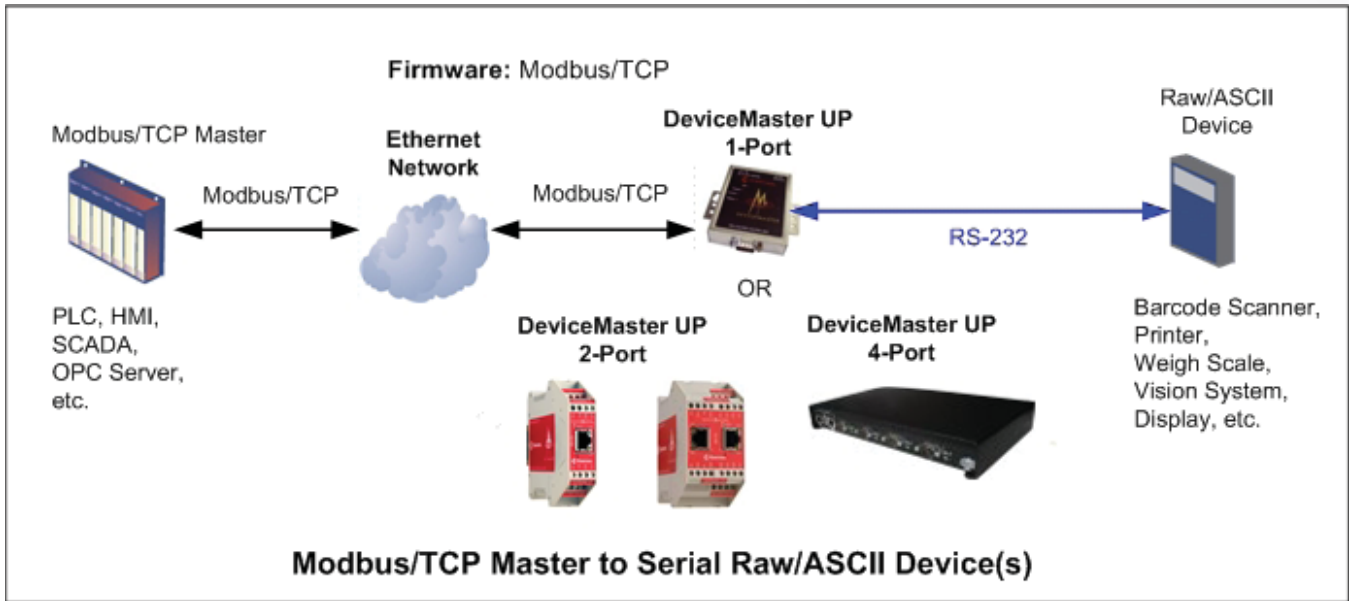

d. And you have Ethernet Raw/ASCII Device(s)

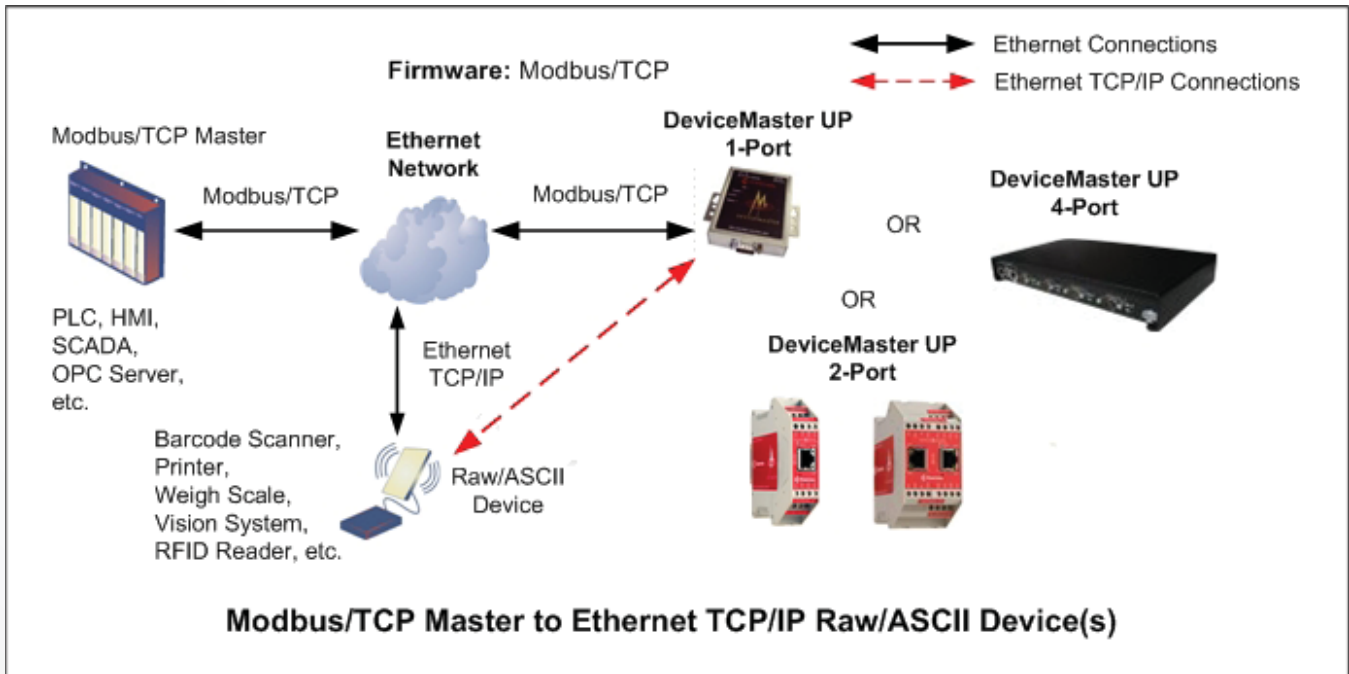

2. You have a Modbus/TCP Slave Controller

This typically includes such controllers as PLCs, OPC Servers, SCADA Systems, HMIs and applications that communicate as a slave via Modbus/TCP.

Due to the nature of master/slave connectivity, the functionality for Modbus/TCP slave controllers is limited to communicating to raw/ASCII devices.

a. And you have Raw/ASCII Serial Device(s)

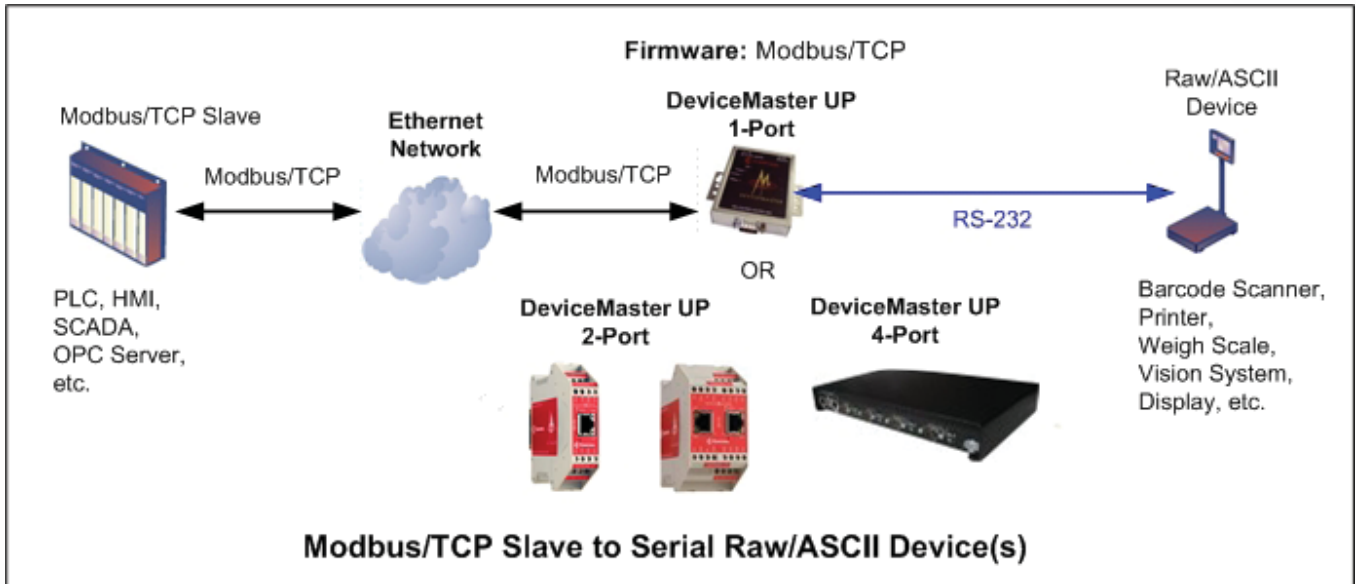

b. And you have Raw/ASCII Ethernet Device(s)

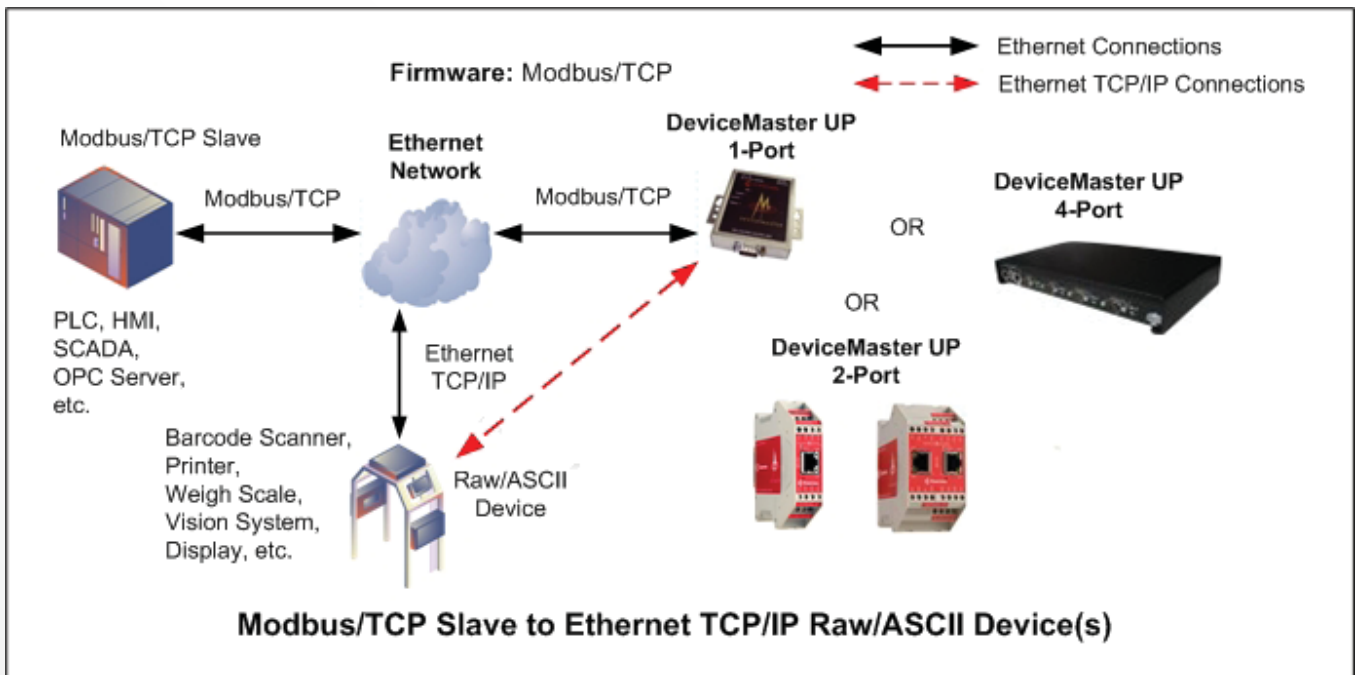

3. You have a Modbus/TCP Master/Slave Controller

This typically includes full-featured controllers such as PLCs, OPC Servers, SCADA Systems, HMIs and applications that can communicate simultaneously as a master and a slave via Modbus/TCP. Utilizing Master/Slave functionality allows the controller and the DeviceMaster UP to operate as peers.

Due to the nature of master/slave connectivity, the functionality for Modbus/TCP master/slave controllers is limited to communicating to raw/ASCII devices.

a. And you have Raw/ASCII Serial Device(s)

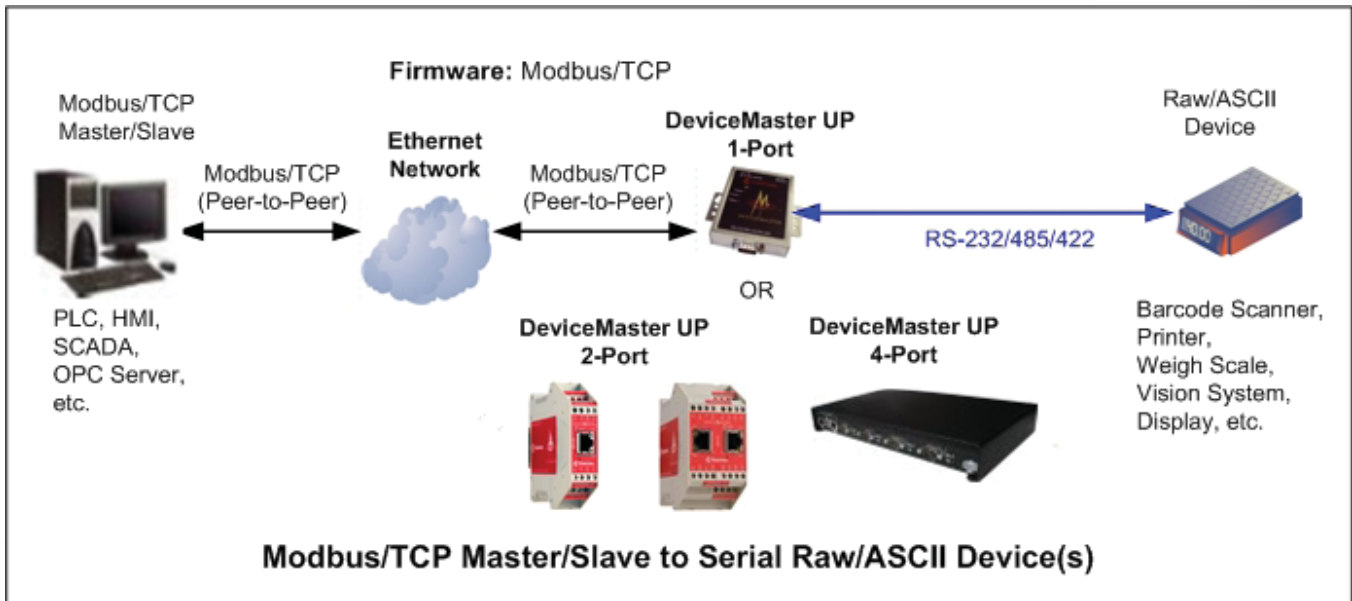

b. And you have Raw/ASCII Ethernet Device(s)

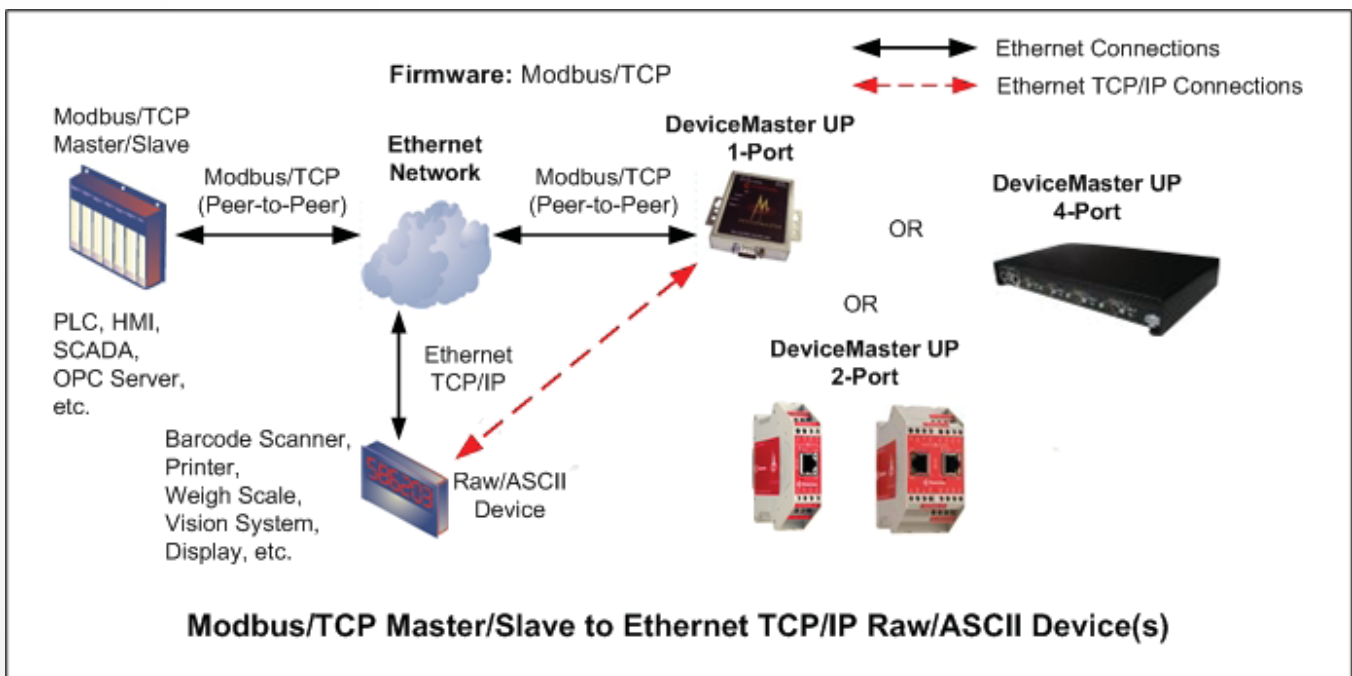

4. You have a Modbus/RTU or Modbus/ASCII Serial Master Controller

This typically includes such controllers as PLCs, SCADA Systems, HMIs and applications that communicate as a master via Modbus/RTU or Modbus/ASCII over a serial or COM port.

a. And you have Serial Modbus/RTU Slave(s)

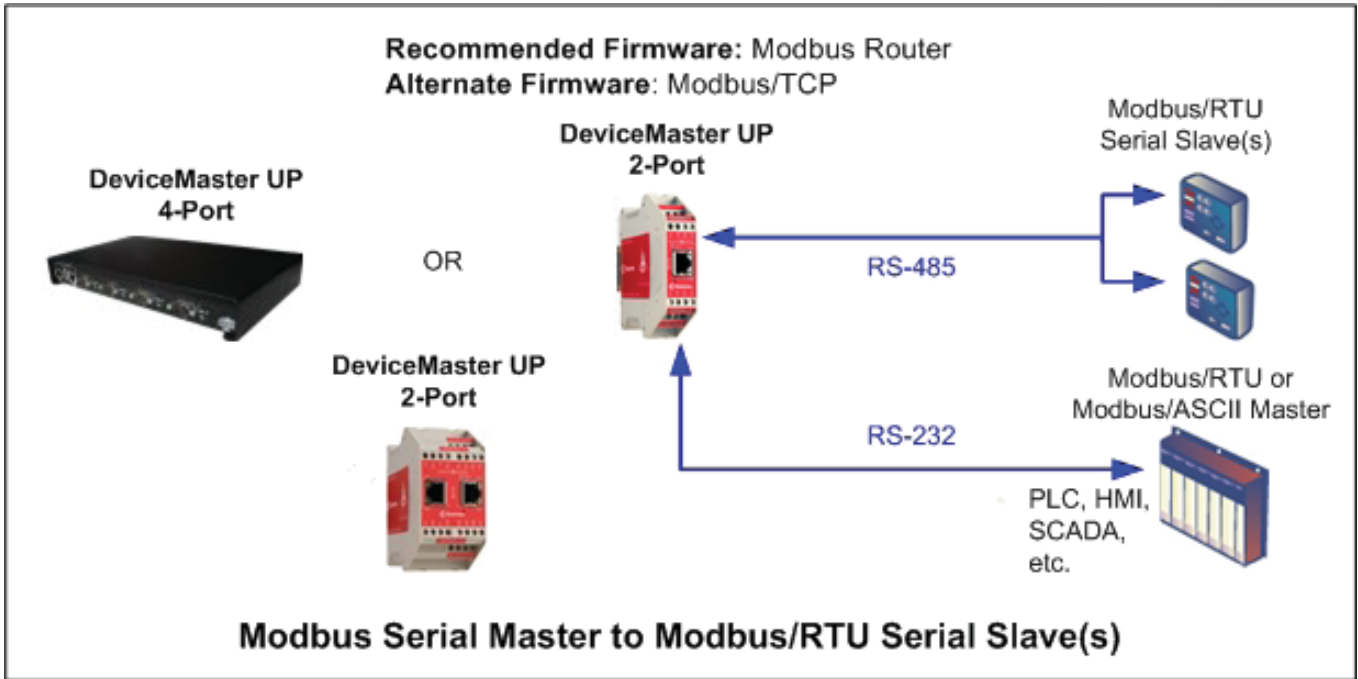

b. And you have Serial Modbus/ASCII Slave(s)

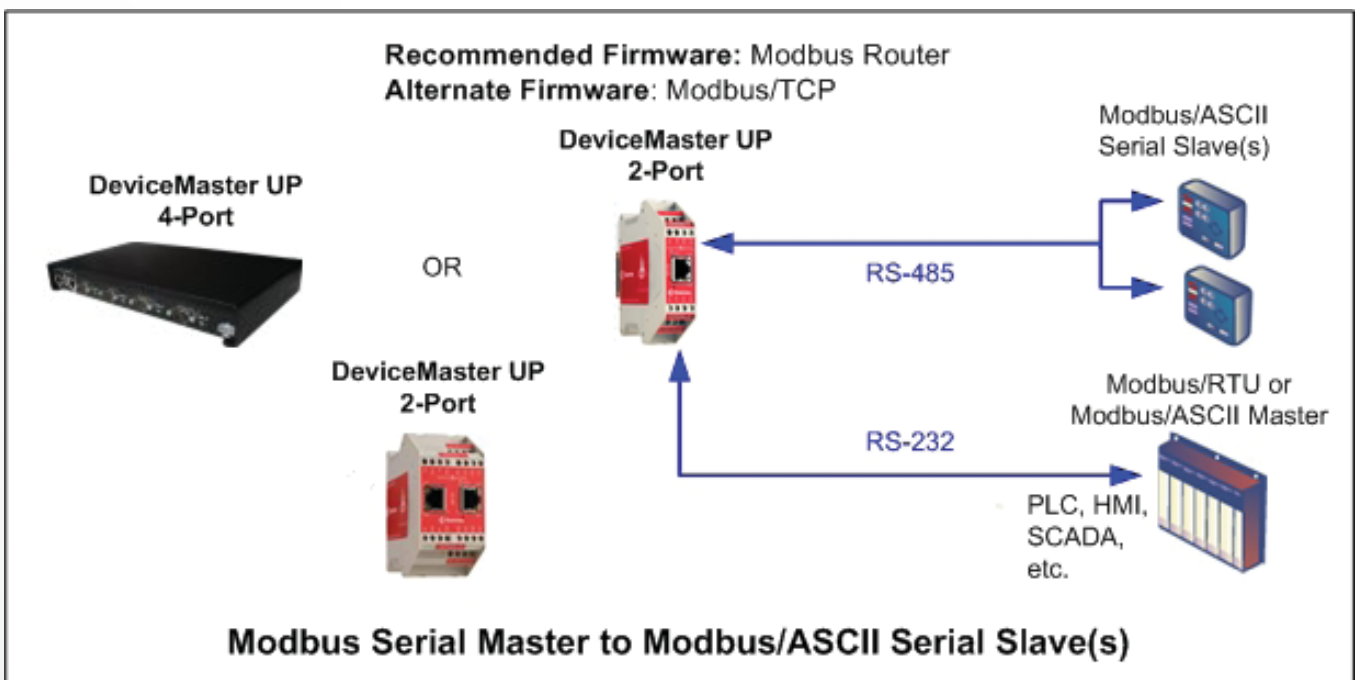

c. *And you have Modbus/TCP Slaves*

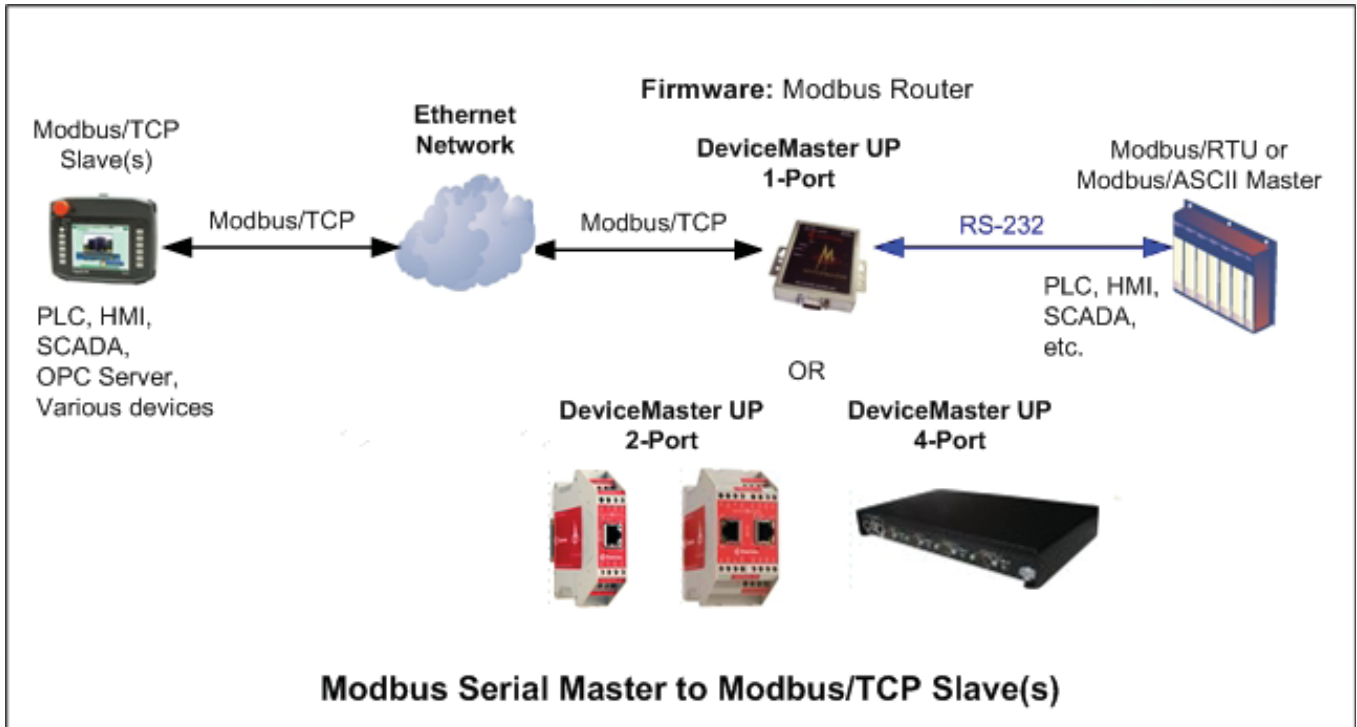

d. *And you have Serial Raw/ASCII Device(s)*

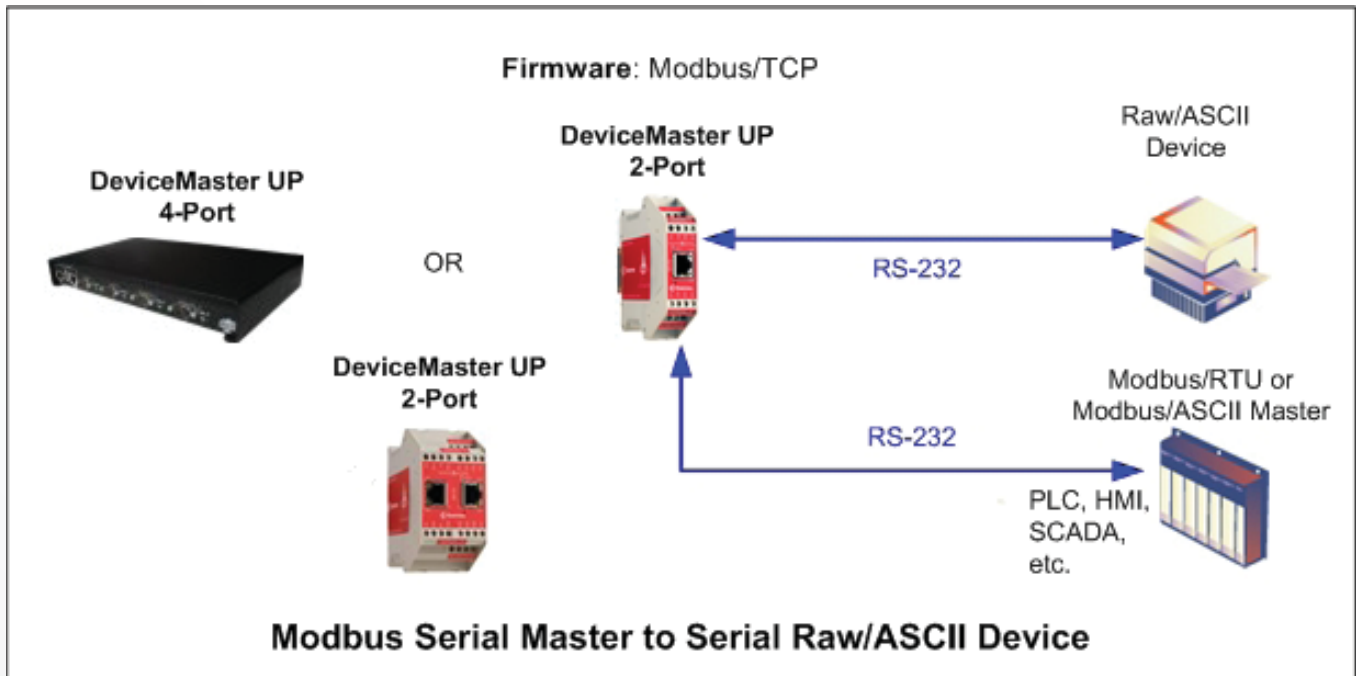

e. And you have Raw/ASCII Ethernet Device(s)

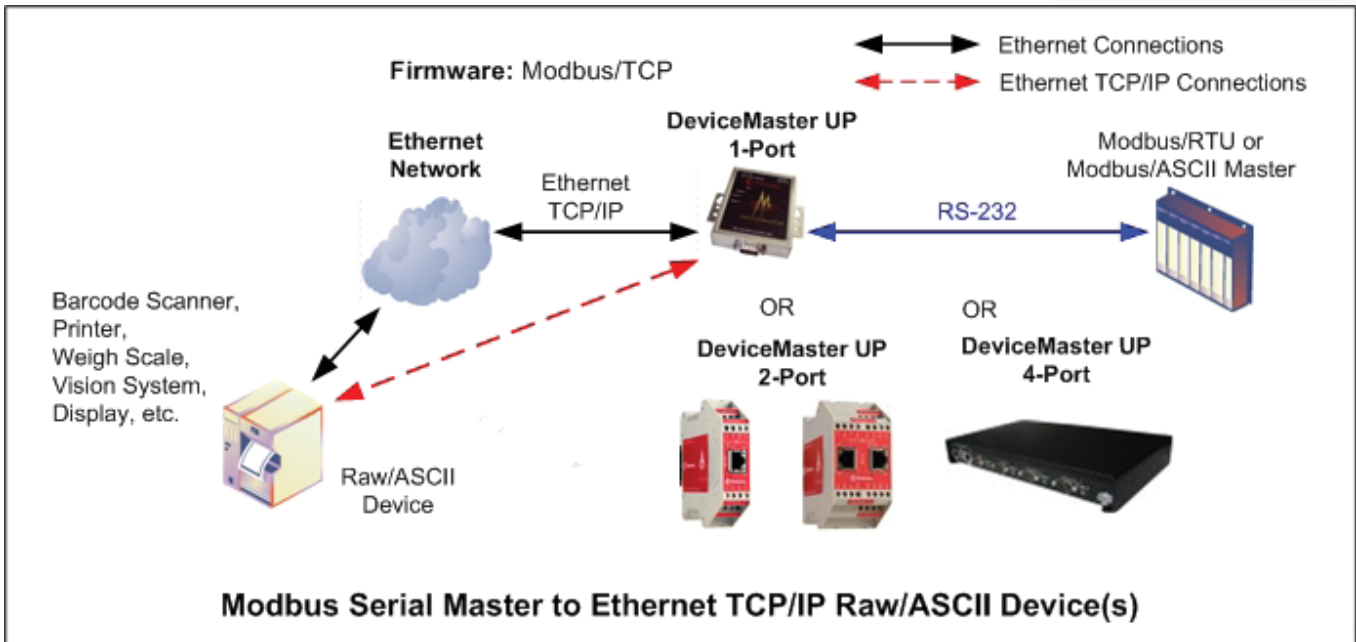

f. And you have Remote Serial Modbus/RTU Slave(s)

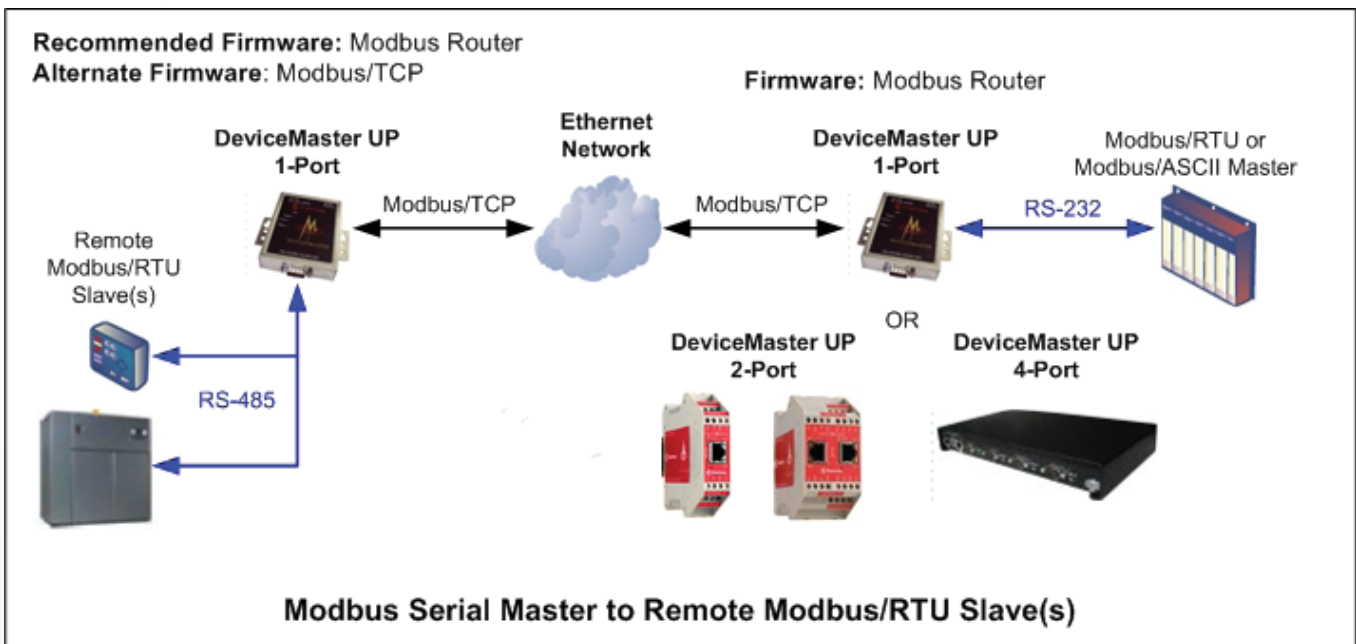

g. And you have Remote Modbus/ASCII Slave(s)

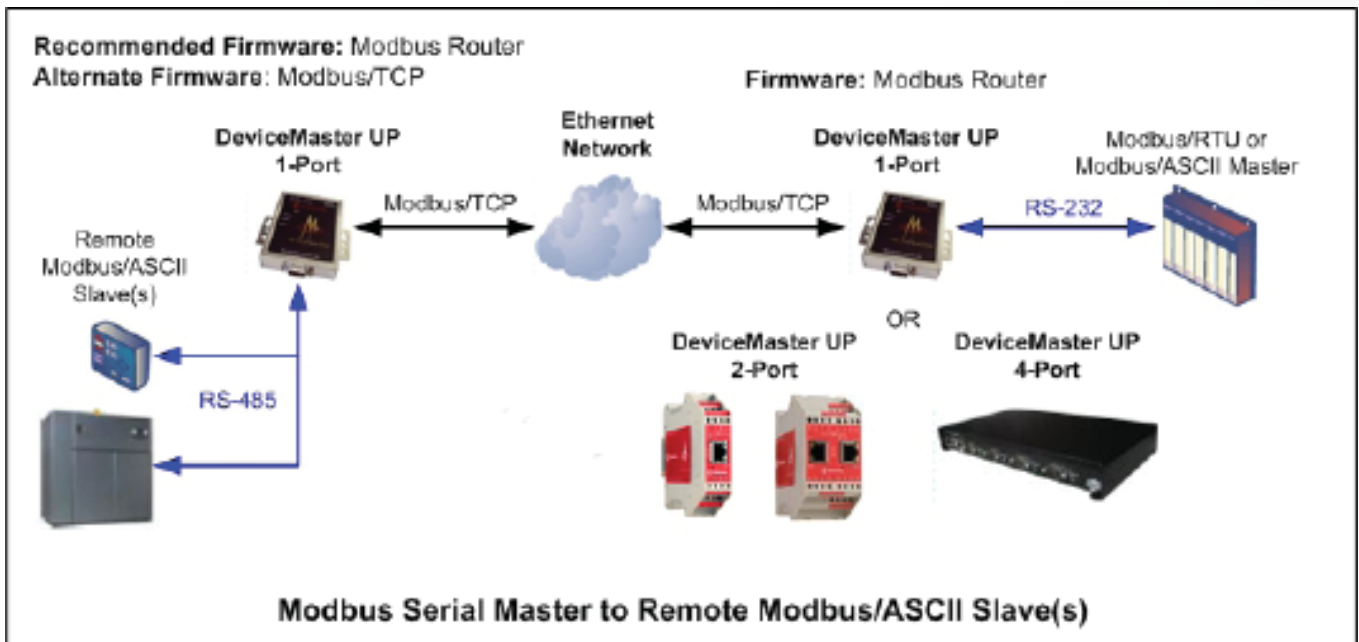

h. And you have Remote Raw/ASCII Serial Device(s)

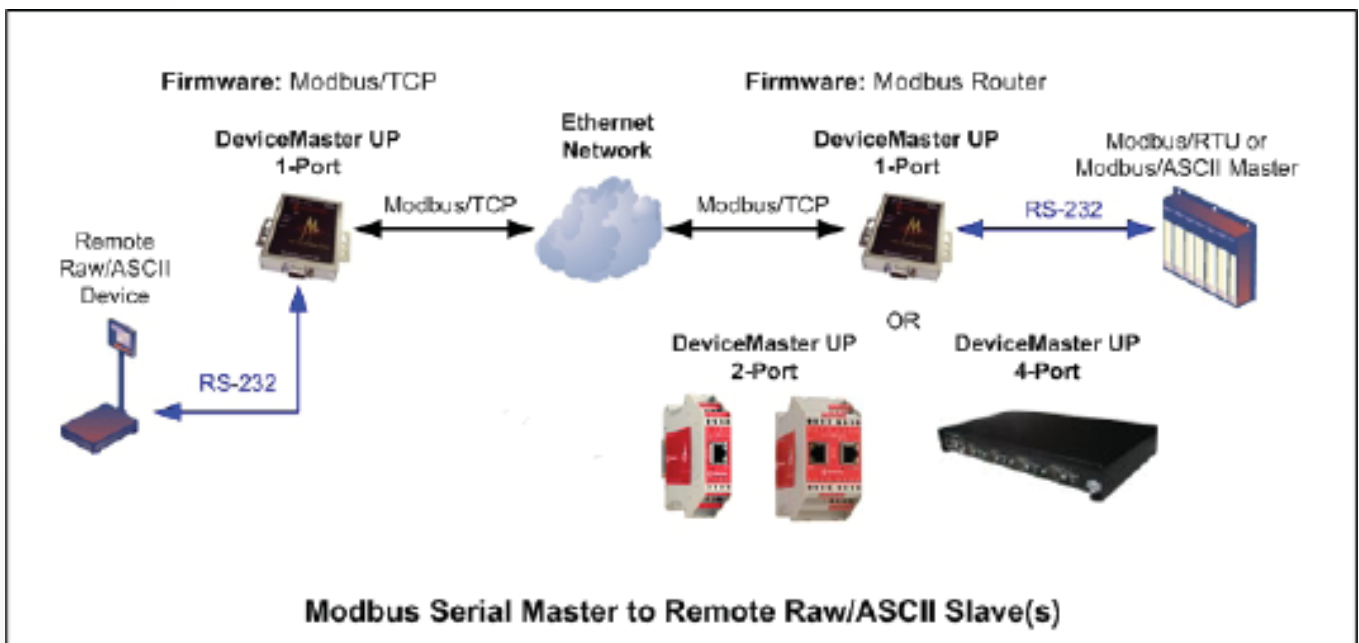

5. You have a Modbus/RTU or Modbus/ASCII Serial Slave Controller

This typically includes such controllers as PLCs, SCADA Systems, HMIs and applications that communicate only as a slave via Modbus/RTU or Modbus/ASCII over a serial or COM port.

Due to the nature of master/slave connectivity, the functionality for Modbus serial slave controllers is limited to communicating to raw/ASCII devices.

a. And you have Raw/ASCII Serial Device(s)

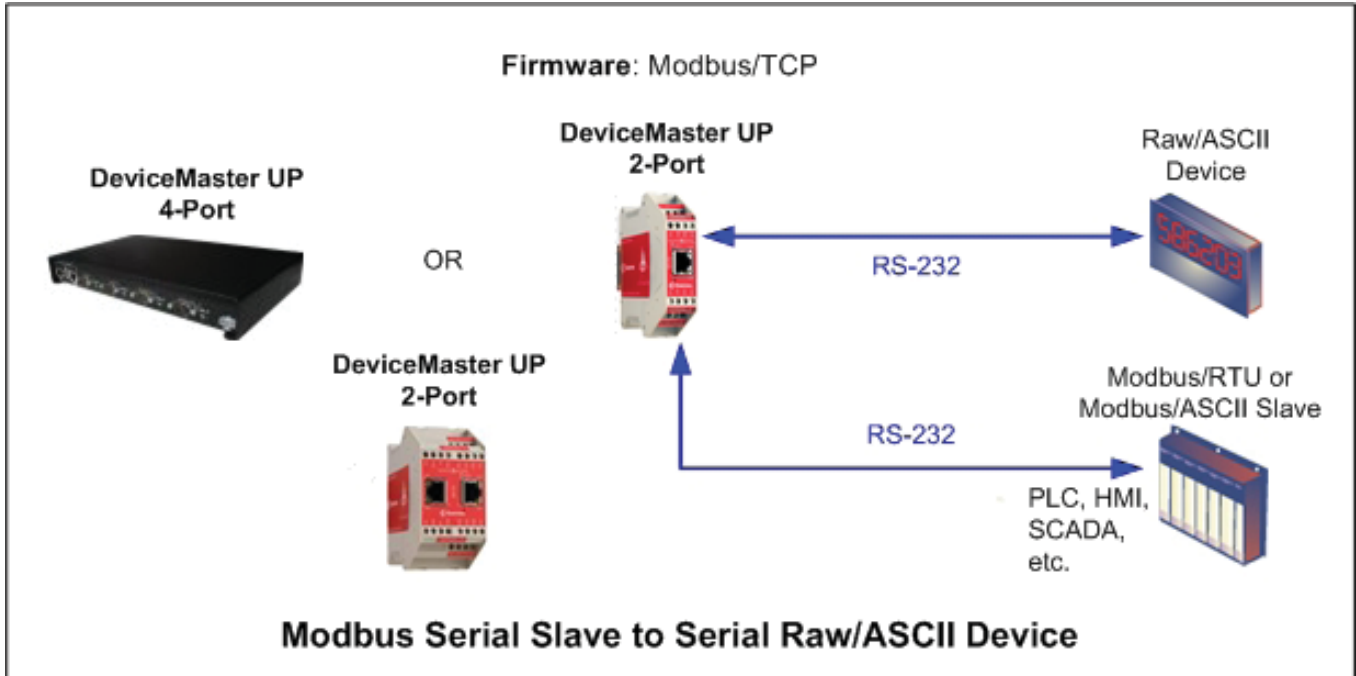

b. And you have Raw/ASCII Ethernet Device(s)

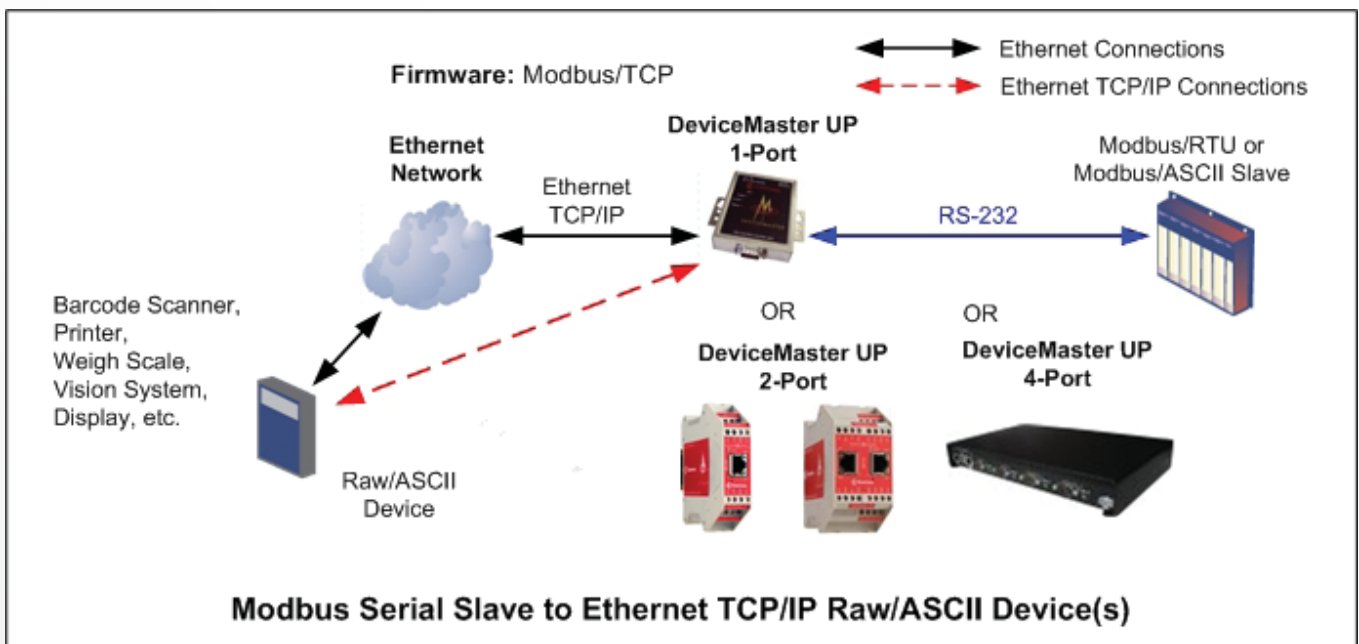

c. And you have Remote Raw/ASCII Serial Device(s)

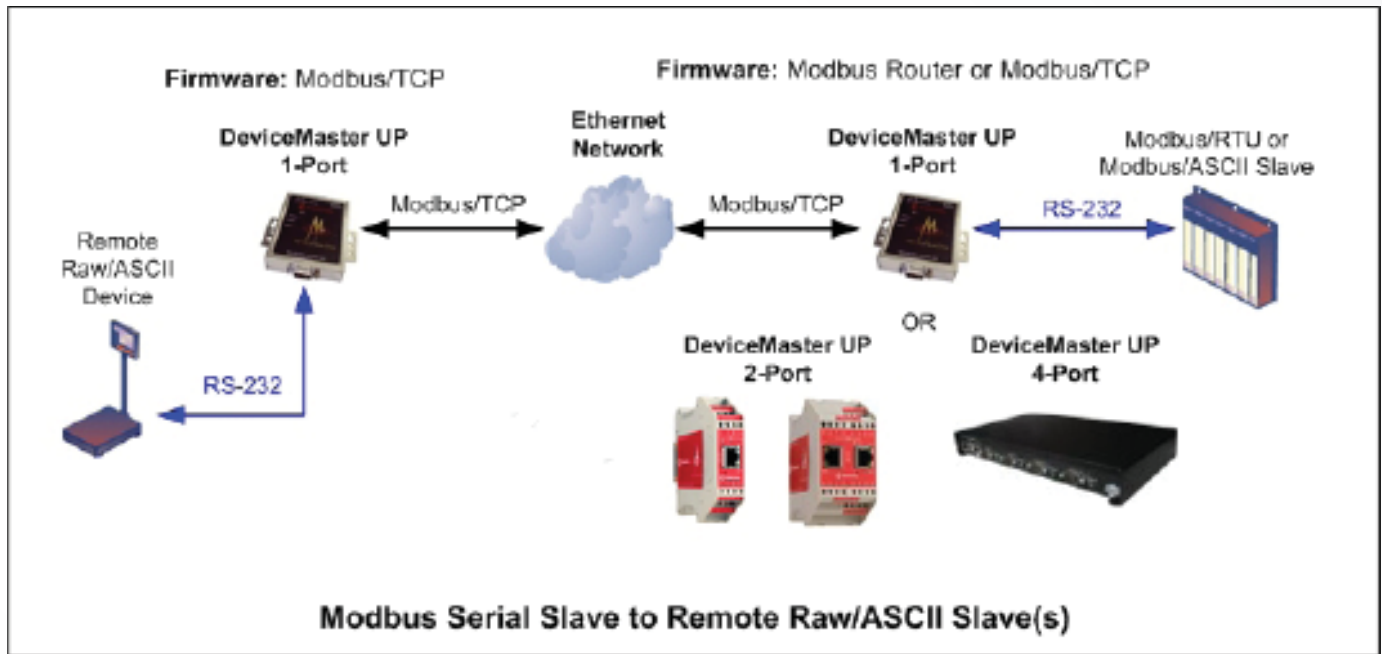

6. You have a Modbus/RTU or Modbus/ASCII over Ethernet TCP/IP Master

This typically includes such controllers as some OPC Servers, SCADA Systems, and applications that communicate as a master via an Ethernet TCP/IP connection or, with the use of a serial port redirector, a COM port.

a. And you have Modbus/RTU Serial Slave(s)

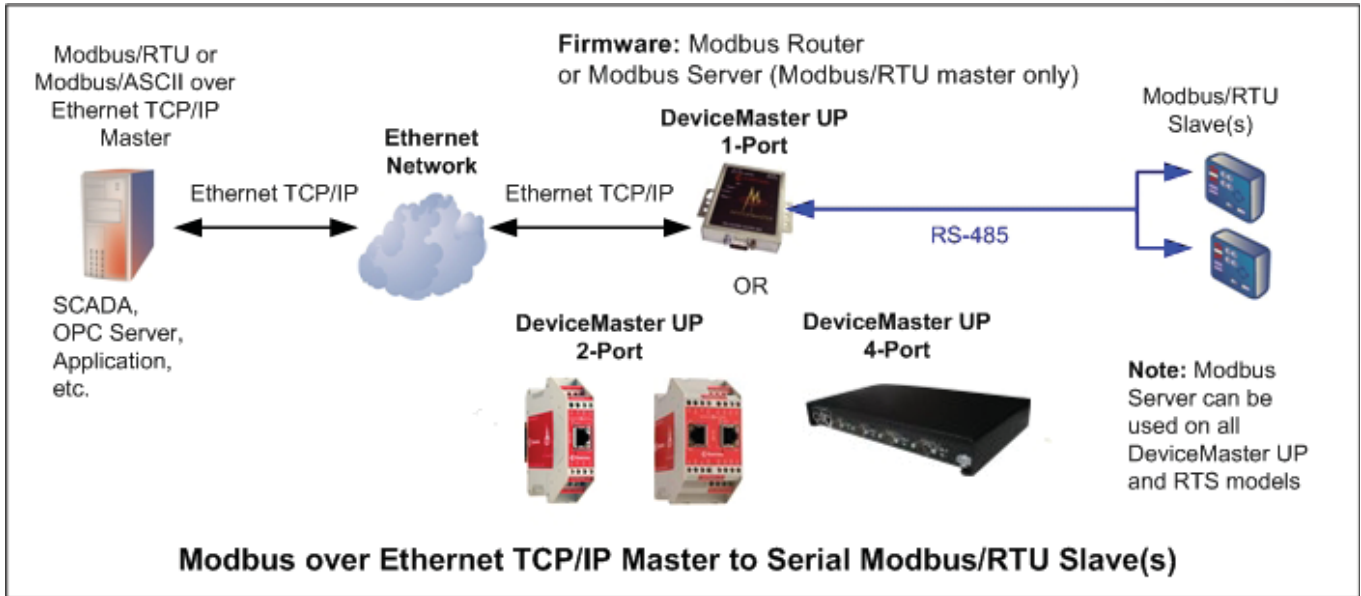

b. And you have Modbus/ASCII Serial Slave(s)

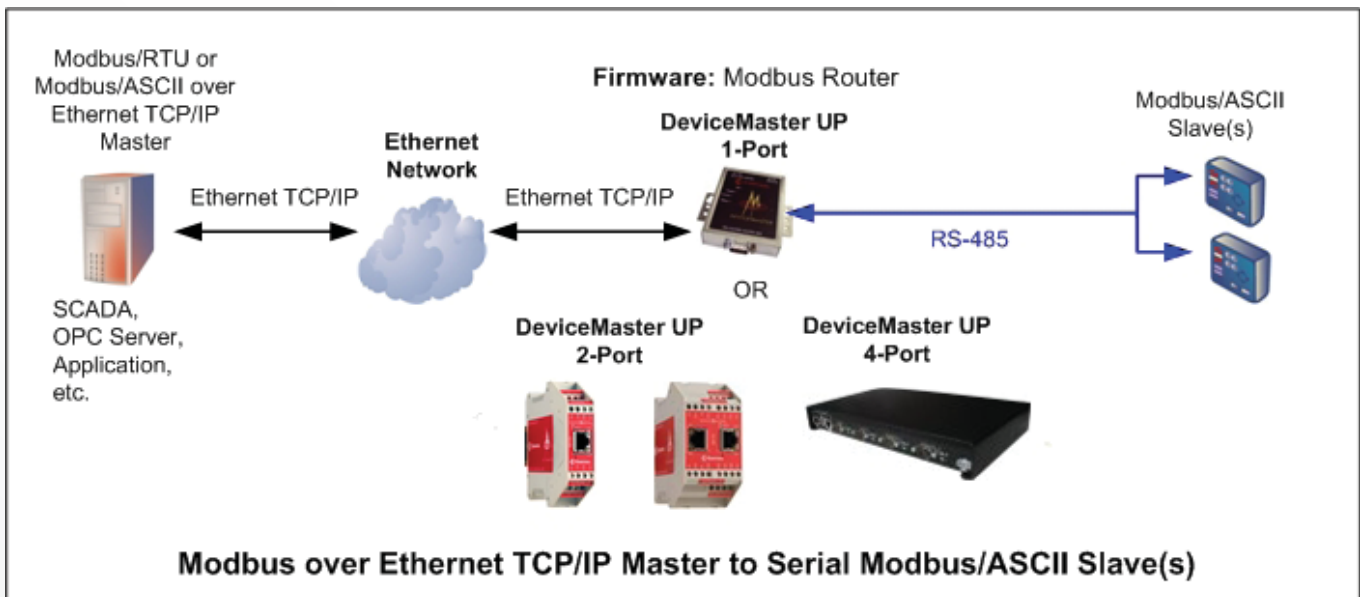

c. And you have Modbus/TCP Slaves

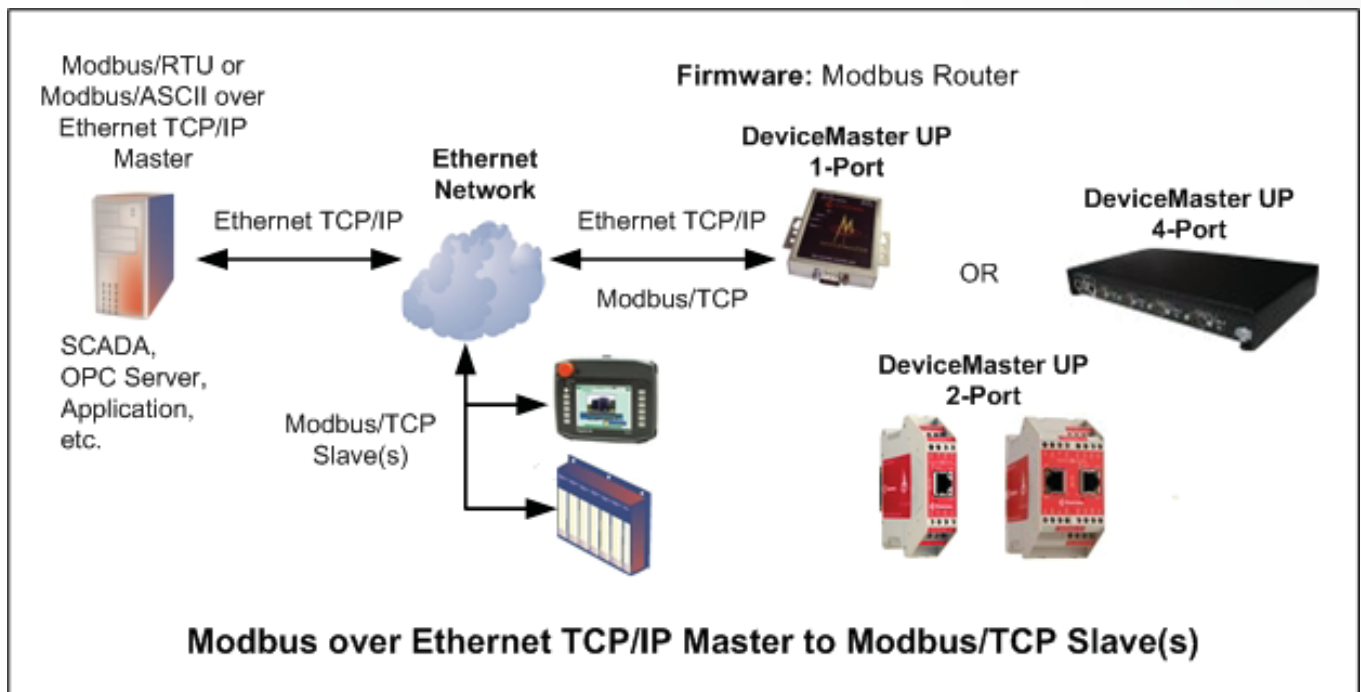

7. You have an Application that Communicates via Raw/ASCII over Ethernet TCP/IP Connection(s)

This typically includes control or data-base management applications that receive and/or transmit raw/ASCII data over an Ethernet TCP/IP connection or, with the use of a serial port redirector, a COM port.

a. And you have Raw/ASCII Serial Device(s)

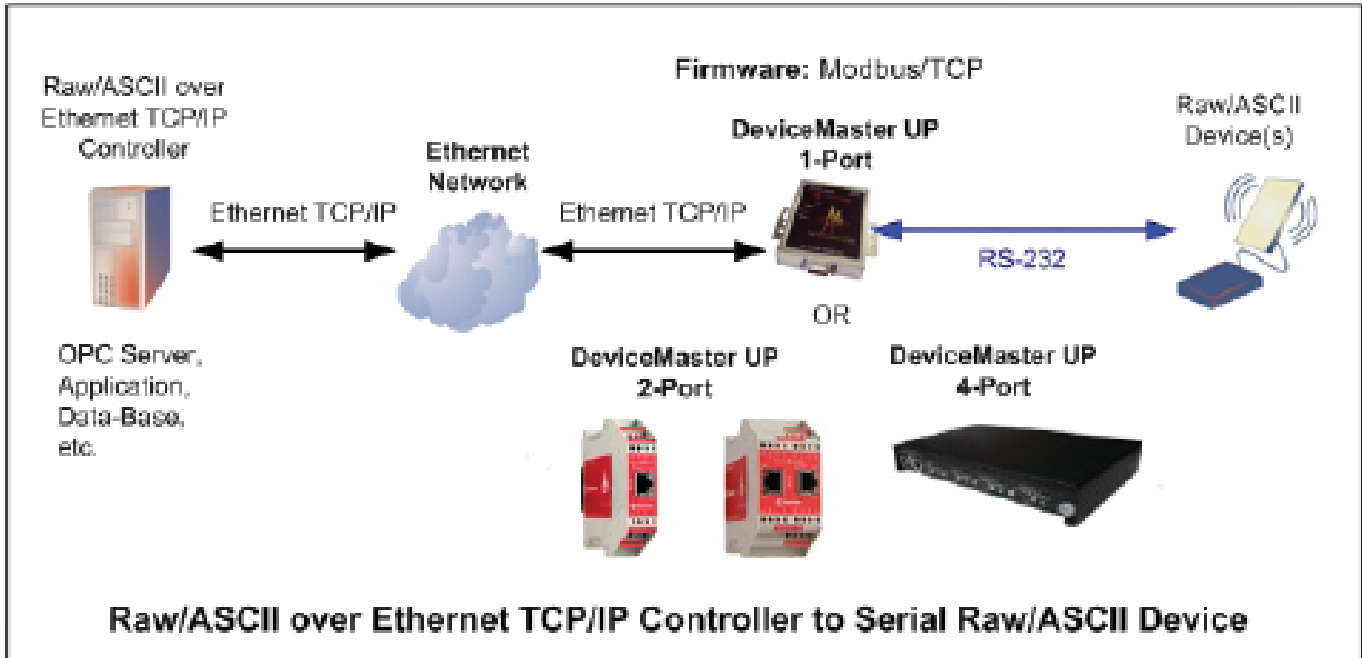

b. And you have Raw/ASCII Ethernet Device(s)

