



---

## **D20/D20S/D22/D23-LB/LS -- LoRaWAN Temperature Sensor User Manual**

last modified by Xiaoling

on 2024/01/25 16:15

---

# Table of Contents

1. Introduction .....	4
1.1 What is D2x-LB/LS LoRaWAN Temperature Sensor .....	4
1.2 Features .....	5
1.3 Specification .....	5
1.4 Sleep mode and working mode .....	6
1.5 Button & LEDs .....	6
1.6 BLE connection .....	7
1.7 Pin Definitions .....	7
1.8 Hardware Variant .....	7
1.9 Mechanical .....	8
1.9.1 for LB version .....	8
1.9.2 for LS version .....	9
2. Configure D2x-LB/LS to connect to LoRaWAN network .....	9
2.1 How it works .....	9
2.2 Quick guide to connect to LoRaWAN server (OTAA) .....	10
2.3 Uplink Payload .....	13
2.3.1 Device Status, FPORT=5 .....	13
2.3.2 Sensor Data, FPORT=2 .....	14
2.4 Payload Decoder file .....	16
2.5 Datalog Feature .....	16
2.5.1 Ways to get datalog via LoRaWAN .....	16
2.5.2 Unix TimeStamp .....	16
2.5.3 Set Device Time .....	17
2.5.4 Datalog Uplink payload (FPORT=3) .....	17
2.6 Temperature Alarm Feature .....	19
2.7 Frequency Plans .....	20
2.8 Firmware Change Log .....	20
3. Configure D2x-LB/LS .....	20
3.1 Configure Methods: .....	20
3.2 General Commands .....	20
3.3 Commands special design for D2x-LB/LS .....	21
3.3.1 Set Transmit Interval Time .....	21
3.3.2 Get Device Status .....	21
3.3.3 Set Alarm Threshold .....	21
3.3.4 Set Alarm Interval .....	22
3.3.5 Get Alarm settings .....	22
3.3.6 Set Interrupt Mode .....	23
3.3.7 Set Power Output Duration .....	23
3.3.8 Multiple VDC collections in one uplink(Since firmware version 1.3.2) .....	24
4. Battery & Power Consumption .....	24
5. OTA firmware update .....	24
6. FAQ .....	25
7. Order Info .....	25
8. Packing Info .....	25
9. Support .....	25



**Table of Contents :**

- [1. Introduction](#)
  - [1.1 What is D2x-LB/LS LoRaWAN Temperature Sensor](#)
  - [1.2 Features](#)
  - [1.3 Specification](#)
  - [1.4 Sleep mode and working mode](#)
  - [1.5 Button & LEDs](#)
  - [1.6 BLE connection](#)
  - [1.7 Pin Definitions](#)
  - [1.8 Hardware Variant](#)
  - [1.9 Mechanical](#)
    - [1.9.1 for LB version](#)
    - [1.9.2 for LS version](#)
- [2. Configure D2x-LB/LS to connect to LoRaWAN network](#)
  - [2.1 How it works](#)
  - [2.2 Quick guide to connect to LoRaWAN server \(OTAA\)](#)
  - [2.3 Uplink Payload](#)
    - [2.3.1 Device Status. FPORT=5](#)
    - [2.3.2 Sensor Data. FPORT=2](#)
      - [Decode corresponding probe color:](#)
      - [Battery:](#)
      - [Temperature RED or Temperature White :](#)
      - [Temperature White:](#)
      - [Temperature Black:](#)
      - [Alarm Flag & MOD & Level of PA8:](#)
  - [2.4 Payload Decoder file](#)
  - [2.5 Datalog Feature](#)
    - [2.5.1 Ways to get datalog via LoRaWAN](#)
    - [2.5.2 Unix TimeStamp](#)
    - [2.5.3 Set Device Time](#)
    - [2.5.4 Datalog Uplink payload \(FPORT=3\)](#)
  - [2.6 Temperature Alarm Feature](#)
  - [2.7 Frequency Plans](#)
  - [2.8 Firmware Change Log](#)
- [3. Configure D2x-LB/LS](#)
  - [3.1 Configure Methods:](#)
  - [3.2 General Commands](#)
  - [3.3 Commands special design for D2x-LB/LS](#)
    - [3.3.1 Set Transmit Interval Time](#)
    - [3.3.2 Get Device Status](#)
    - [3.3.3 Set Alarm Thredhold](#)
    - [3.3.4 Set Alarm Interval](#)
    - [3.3.5 Get Alarm settings](#)
    - [3.3.6 Set Interrupt Mode](#)
    - [3.3.7 Set Power Output Duration](#)
    - [3.3.8 Multiple VDC collections in one uplink\(Since firmware version 1.3.2\)](#)
- [4. Battery & Power Consumption](#)
- [5. OTA firmware update](#)
- [6. FAQ](#)
- [7. Order Info](#)
- [8. Packing Info](#)
- [9. Support](#)

# 1. Introduction

## 1.1 What is D2x-LB/LS LoRaWAN Temperature Sensor

The Dragino D2x-LB/LS is a **LoRaWAN Temperature Sensor** for Internet of Things solution. D2x-LB/LS has 1 ~ 3 temperature probes. D2x-LB/LS will convert the Temperature reading to LoRaWAN wireless data and send to IoT platform via LoRaWAN gateway.

The LoRa wireless technology used in D2x-LB/LS allows device to send data and reach extremely long ranges at low data-rates. It provides ultra-long range spread spectrum communication and high interference immunity whilst minimizing current consumption.

The temperature sensor used in D2x-LB/LS can **measure -55°C ~ 125°C with accuracy ±0.5°C (max ±2.0°C)**.

D2x-LB/LS supports **temperature alarm feature**, user can set temperature alarm for instant notice. D2x-LB/LS supports Datalog feature, it can save the data when there is no LoRaWAN network and uplink when network recover.

D2x-LB/LS has max 3 probes which measure maximum 3 temperature points.

D2x-LB/LS **supports BLE configure** and **wireless OTA update** which make user easy to use.

D2x-LB/LS is powered by **8500mAh Li-SOCI2 battery** or **solar powered + li-on battery** it is designed for long term use up to 5 years.

Each D2x-LB/LS is pre-load with a set of unique keys for LoRaWAN registrations, register these keys to local LoRaWAN server and it will auto connect after power on.

## 1.2 Features

- LoRaWAN 1.0.3 Class A
- Ultra-low power consumption
- 1 ~ 3 External Temperature Probes
- Measure range -55°C ~ 125°C
- Temperature alarm
- Bands: CN470/EU433/KR920/US915/EU868/AS923/AU915/IN865
- Support Bluetooth v5.1 and LoRaWAN remote configure
- Support wireless OTA update firmware
- Uplink on periodically
- Downlink to change configure
- 8500mAh Li/SOCI2 Battery (D2x-LB)
- Solar panel + 3000mAh Li-on battery (D2x-LS)

## 1.3 Specification

### Common DC Characteristics:

- Supply Voltage: Built-in Battery , 2.5v ~ 3.6v
- Operating Temperature: -40 ~ 85°C

### Temperature Sensor:

- Dallas DS18B20
- Range: -55 to + 125°C
- Accuracy ±0.5°C (max ±2.0 °C).

### LoRa Spec:

- Frequency Range, Band 1 (HF): 862 ~ 1020 Mhz
- Max +22 dBm constant RF output vs.
- RX sensitivity: down to -139 dBm.
- Excellent blocking immunity

### Battery:

- Li/SOCI2 un-chargeable battery

- Capacity: 8500mAh
- Self-Discharge: <1% / Year @ 25°C
- Max continuously current: 130mA
- Max boost current: 2A, 1 second

### Power Consumption

- Sleep Mode: 5uA @ 3.3v
- LoRa Transmit Mode: 125mA @ 20dBm, 82mA @ 14dBm

## 1.4 Sleep mode and working mode

**Deep Sleep Mode:** Sensor doesn't have any LoRaWAN activate. This mode is used for storage and shipping to save battery life.

**Working Mode:** In this mode, Sensor will work as LoRaWAN Sensor to Join LoRaWAN network and send out sensor data to server. Between each sampling/tx/rx periodically, sensor will be in IDLE mode), in IDLE mode, sensor has the same power consumption as Deep Sleep mode.

## 1.5 Button & LEDs

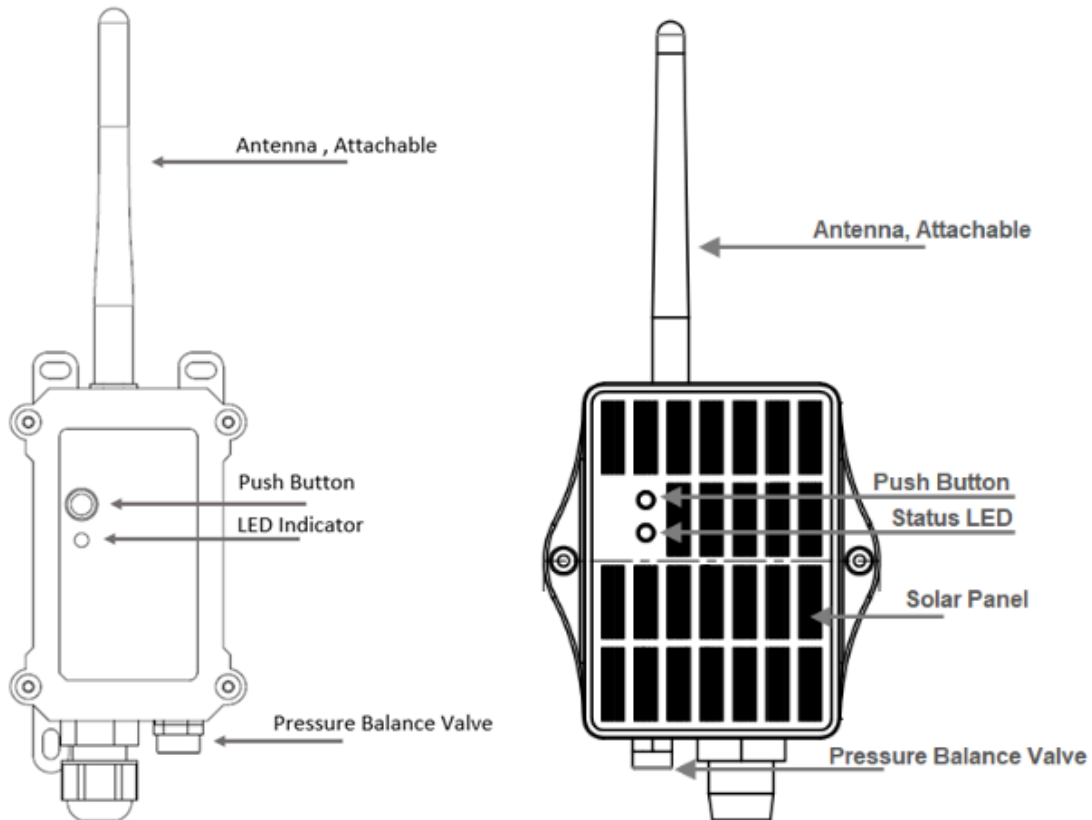

Behavior on ACT	Function	Action
Pressing ACT between 1s < time < 3s	Send an uplink	If sensor is already Joined to LoRaWAN network, sensor will send an uplink packet, <b>blue led</b> will blink once. Meanwhile, BLE module will be active and user can connect via BLE to configure device.
Pressing ACT for more than 3s	Active Device	<b>Green led</b> will fast blink 5 times, device will enter <b>OTA mode</b> for 3 seconds. And then start to JOIN LoRaWAN network.

Fast press ACT 5 times.

Deactivate Device

**Green led** will solidly turn on for 5 seconds after joined in network.

Once sensor is active, BLE module will be active and user can connect via BLE to configure device, no matter if device join or not join LoRaWAN network.

**Red led** will solid on for 5 seconds. Means D2x-LB/LS is in Deep Sleep Mode.

## 1.6 BLE connection

D2x-LB/LS support BLE remote configure.

BLE can be used to configure the parameter of sensor or see the console output from sensor. BLE will be only activate on below case:

- Press button to send an uplink
- Press button to active device.
- Device Power on or reset.

If there is no activity connection on BLE in 60 seconds, sensor will shut down BLE module to enter low power mode.

## 1.7 Pin Definitions

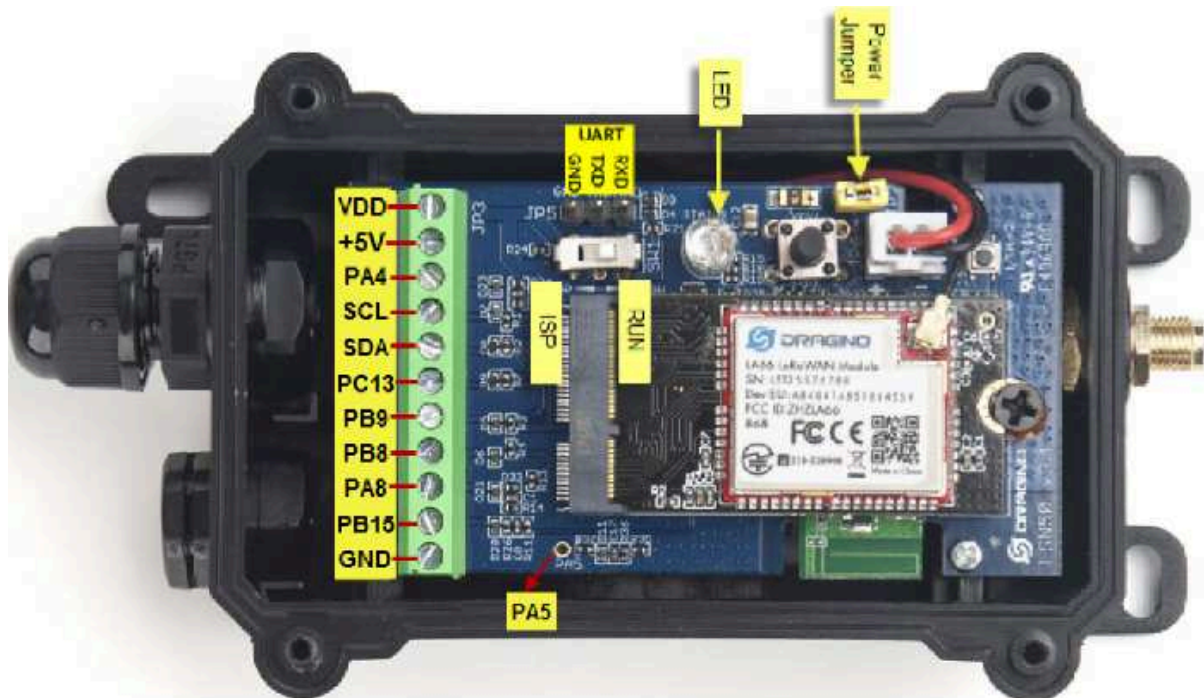

## 1.8 Hardware Variant

Model	Photo	Probe Info
-------	-------	------------

D20-LB/LS



1 x DS28B20 Probe  
Cable Length : 2 meters

D20S-LB/LS



1 x DS28B20 Probe (Suitable for bury in soil)  
Material: TPE, Cable Length: 2meters

D22-LB/LS



2 x DS28B20 Probes  
Cable lengths total 1.5meters per probe  
Cable Drawing: [See This Link](#)

D23-LB/LS



3 x DS28B20 Probes  
Cable lengths total 1.5meters per probe  
Cable Drawing: [See This Link](#)

## 1.9 Mechanical

### 1.9.1 for LB version

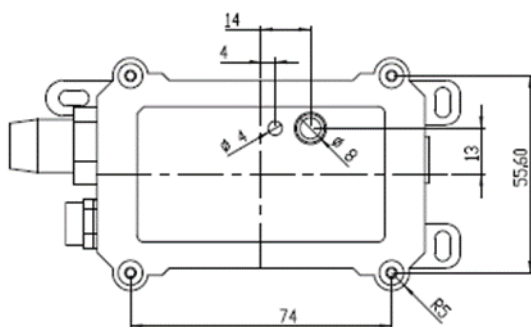



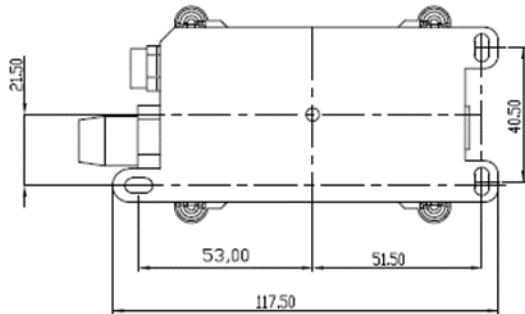
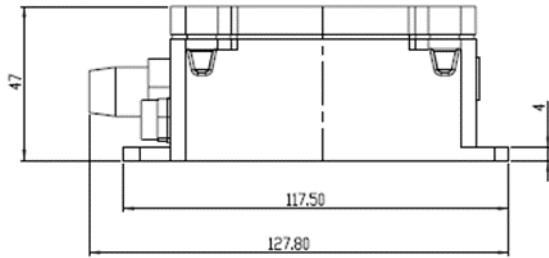

### 1.9.2 for LS version

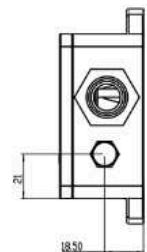
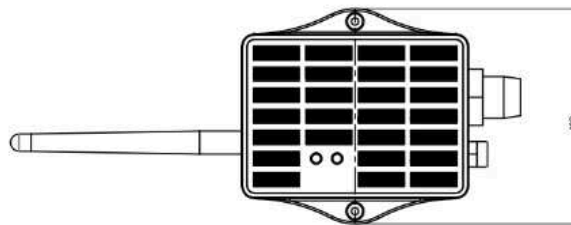
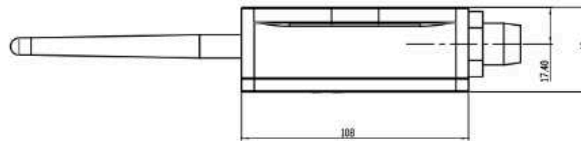

## 2. Configure D2x-LB/LS to connect to LoRaWAN network

### 2.1 How it works

The D2x-LB/LS is configured as **LoRaWAN OTAA Class A** mode by default. It has OTAA keys to join LoRaWAN network. To connect a local LoRaWAN network, you need to input the OTAA keys in the LoRaWAN IoT

server and press the button to activate the D2x-LB/LS. It will automatically join the network via OTAA and start to send the sensor value. The default uplink interval is 20 minutes.

## 2.2 Quick guide to connect to LoRaWAN server (OTAA)

Following is an example for how to join the [TTN v3 LoRaWAN Network](#). Below is the network structure; we use the [LPS8v2](#) as a LoRaWAN gateway in this example.

The LPS8V2 is already set to connected to [TTN network](#), so what we need to now is configure the TTN server.

**Step 1:** Create a device in TTN with the OTAA keys from D2x-LB/LS.

Each D2x-LB/LS is shipped with a sticker with the default device EUI as below:

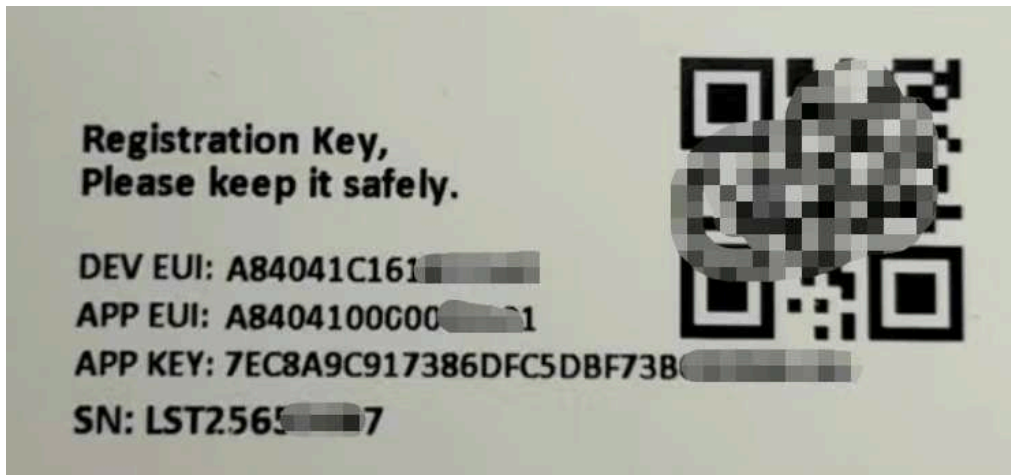

You can enter this key in the LoRaWAN Server portal. Below is TTN screen shot:

[Register the device](#)

## Register end device

From The LoRaWAN Device Repository [Manually](#)

### Preparation

#### Activation mode \*

- Over the air activation (OTAA)
- Activation by personalization (ABP)
- Multicast
- Do not configure activation

#### LoRaWAN version ⓘ \*

MAC V1.0.3

1

#### Network Server address

eu1.cloud.thethings.network

#### Application Server address

eu1.cloud.thethings.network

#### External Join Server ⓘ

Enabled

#### Join Server address

eu1.cloud.thethings.network

Start

2

## Add APP EUI and DEV EUI

## Register end device

From The LoRaWAN Device Repository [Manually](#)

- 1 Basic settings**  
End device ID's, Name and Description
- 2 Network layer settings**  
Frequency plan, regional parameters, end device class and session keys.
- 3 Join settings**  
Root keys, NetID and kek labels.

#### End device ID ⓘ \*

lsnpk01

#### AppEUI ⓘ \*

.. . . . . 00

#### DevEUI ⓘ \*

.. . . . .

#### End device name

LSNPK01

#### End device description

Description for my new end device

Optional end device description; can also be used to save notes about the end device

[Network layer settings >](#)

## Add APP EUI in the application

## Register end device

From The LoRaWAN Device Repository [Manually](#)

- 1 **Basic settings**  
End device ID's, Name and Description
- 2 **Network layer settings**  
Frequency plan, regional parameters, end device class and session keys.
- 3 **Join settings**  
Root keys, NetID and kek labels.

Frequency plan ⓘ\*

Europe 863-870 MHz (SF12 for RX2) ▼

LoRaWAN version ⓘ\*

MAC V1.0.3 ▼

Regional Parameters version ⓘ\*

PHY V1.0.3 REV A ▼

LoRaWAN class capabilities ⓘ

Supports class B

Supports class C

Advanced settings ▼

< Basic settings

Join settings >

### Add APP KEY

## Register end device

From The LoRaWAN Device Repository [Manually](#)

- 1 **Basic settings**  
End device ID's, Name and Description
- 2 **Network layer settings**  
Frequency plan, regional parameters, end device class and session keys.
- 3 **Join settings**  
Root keys, NetID and kek labels.

Root keys

AppKey ⓘ\*

BD 72 1D AC F3 CC AB 67 72 8D 7A F5 4D DF 30 8B ↻

Advanced settings ▼

< Network layer settings

Add end device

## Step 2: Activate on D2x-LB/LS

Press the button for 5 seconds to activate the D2x-LB/LS.

**Green led** will fast blink 5 times, device will enter **OTA mode** for 3 seconds. And then start to JOIN LoRaWAN network. **Green led** will solidly turn on for 5 seconds after joined in network.

After join success, it will start to upload messages to TTN and you can see the messages in the panel.

## 2.3 Uplink Payload

### 2.3.1 Device Status, FPORT=5

Users can use the downlink command(**0x26 01**) to ask D2x-LB/LS to send device configure detail, include device configure status. D2x-LB/LS will uplink a payload via FPort=5 to server.

The Payload format is as below.

Device Status (FPORT=5)					
Size (bytes)	1	2	1	1	2
Value	Sensor Model	Firmware Version	Frequency Band	Sub-band	BAT

Example parse in TTNv3

The screenshot shows the TTNv3 interface with a 'Live data' message. The message is a 'Forward uplink data message' received at 14:56:21. The payload is a JSON object: { BAT: 3.594, FIRMWARE\_VERSION: "1.3.0", FREQUENCY\_BAND: "EU868", SENSOR\_MODEL: "D23-LB", SUB\_BAND: "NULL" }. The interface includes navigation tabs (Overview, Live data, Messaging, Location, Payload formatters, Claiming, General settings) and controls for the stream (Verbose stream, Export as JSON, Pause, Clear).

**Sensor Model:** For D2x-LB/LS, this value is 0x19

**Firmware Version:** 0x0100, Means: v1.0.0 version

**Frequency Band:**

0x01: EU868

0x02: US915

0x03: IN865

0x04: AU915

0x05: KZ865

0x06: RU864

0x07: AS923

0x08: AS923-1

0x09: AS923-2

0x0a: AS923-3

0x0b: CN470

0x0c: EU433

0x0d: KR920

0x0e: MA869

### Sub-Band:

AU915 and US915:value 0x00 ~ 0x08

CN470: value 0x0B ~ 0x0C

Other Bands: Always 0x00

### Battery Info:

Check the battery voltage.

Ex1: 0x0B45 = 2885mV

Ex2: 0x0B49 = 2889mV

## 2.3.2 Sensor Data. FPORT=2

D2x-LB/LS will uplink below payload via FPORT=2 after Joined LoRaWAN Network.

Size(bytes)	2	2	2	1	2	2
Value	Battery	Temp_ Red or Temp _White	ignore	Alarm Flag & MOD& Level of PA8	Temp_White	Temp_Black

### Payload per each model.

Equipment	Size (bytes)	2	2	2	1	2	2
D20	Value	Battery	Temp-Red	Ignore	Alarm Flag	/	/
D22	Value	Battery	Temp-White	Ignore	Alarm Flag	Temp-Red	/
D23	Value	Battery	Temp-White	Ignore	Alarm Flag	Temp-Red	Temp-Black

↑2 ↓2 • Last activity 1 minute ago

Overview **Live data** Messaging Location Payload formatters Claiming General settings

Time Type Data preview Verbose stream  Export as JSON  Pause  Clear

↓ 14:55:36 Schedule data downlink for t... DevAddr: 26 0B 82 DB <> Rx1 Delay: 5

↑ 14:55:35 Forward uplink data message Payload: { BatV: 3.6, Door\_status: "OPEN", EXTI\_Trigger: "FALSE", TempC1: 26.6, TempC2: 26.3, TempC3: 26.6 } 0E 10 01 0A 00 00 0

### Decode corresponding probe color:

#### D20:

Red <--> C1

#### D22:

White <--> C1 , Red <--> C2

#### D23:

White <-->C1 , Red <--> C2 , Black <--> C3

### Battery:

Sensor Battery Level.

Ex1: 0x0B45 = 2885mV

Ex2: 0x0B49 = 2889mV

### Temperature RED or Temperature White :

**This point to the Red probe in D20-LB or the probe of D22-LB/D23-LB White**

#### Example:

If payload is: 0105H: (0105 & 8000 == 0), temp = 0105H /10 = 26.1 degree

If payload is: FF3FH : (FF3F & 8000 == 1) , temp = (FF3FH - 65536)/10 = -19.3 degrees.

(FF3F & 8000: Judge whether the highest bit is 1, when the highest bit is 1, it is negative)

### Temperature White:

**This point to the Red probe in D22-LB/D23-LB.**

**If it is D20-LB, the value is 0x7FFF, which is 327.67.**

#### Example:

If payload is: 0105H: (0105 & 8000 == 0), temp = 0105H /10 = 26.1 degree

If payload is: FF3FH : (FF3F & 8000 == 1) , temp = (FF3FH - 65536)/10 = -19.3 degrees.

(FF3F & 8000: Judge whether the highest bit is 1, when the highest bit is 1, it is negative)

## Temperature Black:

**This point to the BLACK probe in D23-LB**

**If it is D20-LB/D22-LB, the value is 0x7FFF, which is 327.67.**

### Example:

If payload is: 0105H: (0105 & 8000 == 0), temp = 0105H /10 = 26.1 degree

If payload is: FF3FH : (FF3F & 8000 == 1) , temp = (FF3FH - 65536)/10 = -19.3 degrees.

(FF3F & 8000: Judge whether the highest bit is 1, when the highest bit is 1, it is negative)

## Alarm Flag & MOD & Level of PA8:

### Example:

If payload & 0x01 = 0x01 --> This is an Alarm Message. It means that the temperature exceed the alarm value or trigger an interrupt.

If payload & 0x01 = 0x00 --> This is a normal uplink message, no alarm.

If payload & 0x80 >> 7 = 0x01 --> The PA8 is low level.

If payload & 0x80 >> 7 = 0x00 --> The PA8 is high level.

If payload >> 2 = 0x00 --> means MOD=1, This is a sampling uplink message.

If payload >> 2 = 0x31 --> means MOD=31, this message is a reply message for polling, this message contains the alarm settings. see [this link](#) for detail.

## 2.4 Payload Decoder file

In TTN, use can add a custom payload so it shows friendly.

In the page **Applications --> Payload Formats --> Custom --> decoder** to add the decoder from:

<https://github.com/dragino/dragino-end-node-decoder/tree/main/D20-LB%26D20S-LB%26D22-LB%26D23-LB>

## 2.5 Datalog Feature

Datalog Feature is to ensure IoT Server can get all sampling data from Sensor even if the LoRaWAN network is down. For each sampling, D2x-LB/LS will store the reading for future retrieving purposes.

### 2.5.1 Ways to get datalog via LoRaWAN

Set **PNACKMD=1**, D2x-LB/LS will wait for ACK for every uplink, when there is no LoRaWAN network, D2x-LB/LS will mark these records with non-ack messages and store the sensor data, and it will send all messages (10s interval) after the network recovery.

- a) D2x-LB/LS will do an ACK check for data records sending to make sure every data arrive server.
- b) D2x-LB/LS will send data in **CONFIRMED Mode** when PNACKMD=1, but D2x-LB/LS won't re-transmit the packet if it doesn't get ACK, it will just mark it as a NONE-ACK message. In a future uplink if D2x-LB/LS gets a ACK, D2x-LB/LS will consider there is a network connection and resend all NONE-ACK Message.

### 2.5.2 Unix TimeStamp

D2x-LB/LS uses Unix TimeStamp format based on



<b>Size (bytes)</b>	<b>4</b>	<b>1</b>
<b>DeviceTimeAns Payload</b>	32-bit unsigned integer : Seconds since epoch*	8bits unsigned integer: fractional-second in $\frac{1}{2}^8$ second steps

Figure 10 : DeviceTimeAns payload format

User can get this time from link: <https://www.epochconverter.com/> :

Below is the converter example

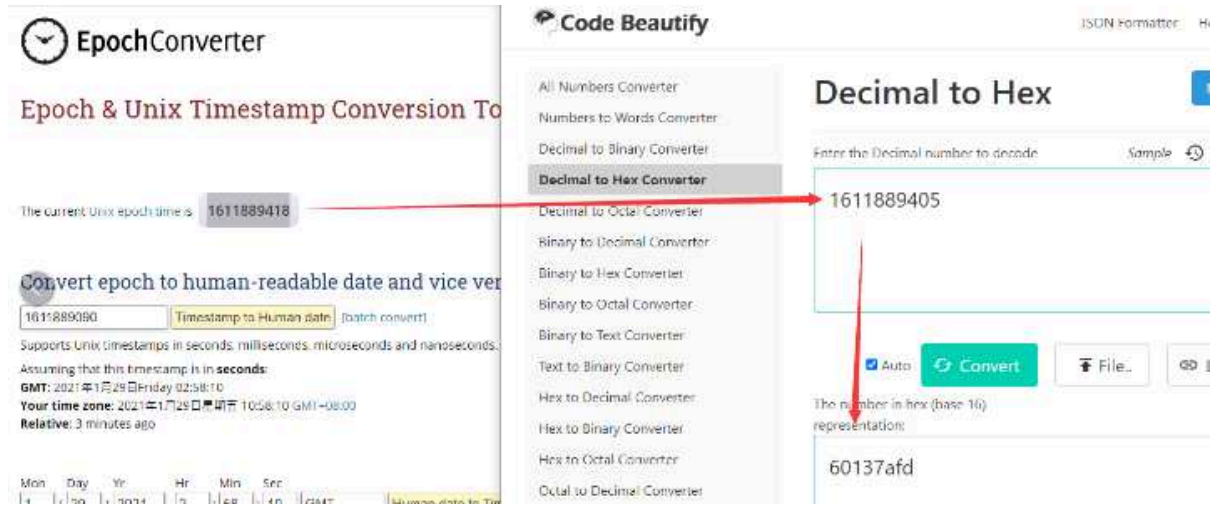

So, we can use AT+TIMESTAMP=1611889405 or downlink 3060137afd00 to set the current time 2021 - Jan -- 29 Friday 03:03:25

### 2.5.3 Set Device Time

User need to set **SYNCMOD=1** to enable sync time via MAC command.

Once D2x-LB/LS Joined LoRaWAN network, it will send the MAC command (DeviceTimeReq) and the server will reply with (DeviceTimeAns) to send the current time to D2x-LB/LS. If D2x-LB/LS fails to get the time from the server, D2x-LB/LS will use the internal time and wait for next time request (AT+SYNCTDC to set the time request period, default is 10 days).

**Note: LoRaWAN Server need to support LoRaWAN v1.0.3(MAC v1.0.3) or higher to support this MAC command feature, Chirpstack,TTN V3 v3 and loriot support but TTN V3 v2 doesn't support. If server doesn't support this command, it will through away uplink packet with this command, so user will lose the packet with time request for TTN V3 v2 if SYNCMOD=1.**

### 2.5.4 Datalog Uplink payload (FPORT=3)

The Datalog poll reply uplink will use below payload format.

**Retrieval data payload:**

Size(bytes)	2	2	2	1	4
Value	Temp_Black	Temp_White	Temp_Red or Temp_White	Poll message flag & Alarm Flag& Level of PA8	Unix Time Stamp

### Poll message flag & Ext:

Bits	7	6	[5:2]	1	0
mean	No ACK Message	Poll Message Flag	Reserved	Level of PA8	Alarm Flag

**No ACK Message:** 1: This message means this payload is fromn Uplink Message which doesn't get ACK from the server before ( for **PNACKMD=1** feature)

**Poll Message Flag:** 1: This message is a poll message reply.

- Poll Message Flag is set to 1.
- Each data entry is 11 bytes, to save airtime and battery, devices will send max bytes according to the current DR and Frequency bands.

For example, in US915 band, the max payload for different DR is:

- a) **DR0:** max is 11 bytes so one entry of data
- b) **DR1:** max is 53 bytes so devices will upload 4 entries of data (total 44 bytes)
- c) **DR2:** total payload includes 11 entries of data
- d) **DR3:** total payload includes 22 entries of data.

If devise doesn't have any data in the polling time. Device will uplink 11 bytes of 0

### Example:

If D2x-LB/LS has below data inside Flash:

```
Stop Tx events when read sensor data
8031200 2023/5/24 07:20:07 3600 temp1=26.4 temp2=26.1 temp3=26.4 level:low status:false
8031210 2023/5/24 07:20:22 3594 temp1=26.5 temp2=26.1 temp3=26.5 level:low status:false
8031220 2023/5/24 07:20:38 3594 temp1=26.5 temp2=26.1 temp3=26.5 level:low status:false
8031230 2023/5/24 07:21:01 3600 temp1=26.5 temp2=26.1 temp3=26.5 level:low status:true
8031240 2023/5/24 07:22:06 3600 temp1=26.5 temp2=26.1 temp3=26.5 level:high status:true
8031250 2023/5/24 07:22:27 3600 temp1=26.5 temp2=26.2 temp3=26.5 level:low status:true
8031260 2023/5/24 07:22:45 3594 temp1=26.6 temp2=26.2 temp3=26.5 level:low status:false
8031270 2023/5/24 07:22:57 3594 temp1=26.5 temp2=26.2 temp3=26.5 level:low status:false
Start Tx events
```

OK

If user sends below downlink command: 31646DBAA0646DBB5405

Where : Start time: 646DBAA0 = time 23/5/24 07:20:00

Stop time: 646DBB54= time 23/5/24 07:23:00

**D2x-LB/LS will uplink this payload.**

↑ 11 ↓ 2 • Last activity 21 seconds ago

Overview **Live data** Messaging Location Payload formatters Claiming General settings

Time	Type	Data preview
↑ 15:38:27	Forward uplink data message	DATALOG: "[26.4,26.1,26.4,Low,False,2023-05-24 07:20:07],[26.5,26.1,26.5,Low,False,2023-05-24 07:20:22],[26.5,26.1,26.5,Low,Fa]
↑ 15:38:27	Successfully processed data ...	DevAddr: 26 08 82 DB <>
↑ 15:22:57	Forward uplink data message	DevAddr: 26 08 82 DB <>  Payload: { BatV: 3.594, Door_status: "OPEN", EXTI_Trigger: "FALSE", TempC1: 26.5, TempC2: 26.2, Te
↑ 15:22:57	Successfully processed data ...	DevAddr: 26 08 82 DB <>
↑ 15:22:45	Forward uplink data message	DevAddr: 26 08 82 DB <>  Payload: { BatV: 3.594, Door_status: "OPEN", EXTI_Trigger: "FALSE", TempC1: 26.6, TempC2: 26.2, Te
↑ 15:22:45	Successfully processed data ...	DevAddr: 26 08 82 DB <>
↑ 15:22:27	Forward uplink data message	DevAddr: 26 08 82 DB <>  Payload: { BatV: 3.6, Door_status: "OPEN", EXTI_Trigger: "TRUE", TempC1: 26.5, TempC2: 26.2, TempC

01 08 01 05 01 08 40 64 6D BA A7 01 09 01 05 01 09 40 64 6D BA B6 01 09 01 05 01 09 40 64 6D BA C6 01 09  
 01 05 01 09 41 64 6D BA DD 01 09 01 05 01 09 43 64 6D BB 1E 01 09 01 06 01 09 41 64 6D BB 33 01 09 01 06  
 01 0A 40 64 6D BB 45 01 09 01 06 01 09 40 64 6D BB 51

Where the first 11 bytes is for the first entry:

01 08 01 05 01 08 40 64 6D BA A7

**Temp\_Black**=0x0108/10=26.4

**Temp\_White**=0x0105/10=26.1

**Temp\_Red or White**=0x0108/10=26.4

**poll message flag & Alarm Flag & Level of PA8**=0x40,means reply data,sampling uplink message,the PA8 is low level.

**Unix time** is 0x646DBAA7=1684912807s=23/5/24 07:20:07

## 2.6 Temperature Alarm Feature

D2x-LB/LS work flow with Alarm feature.

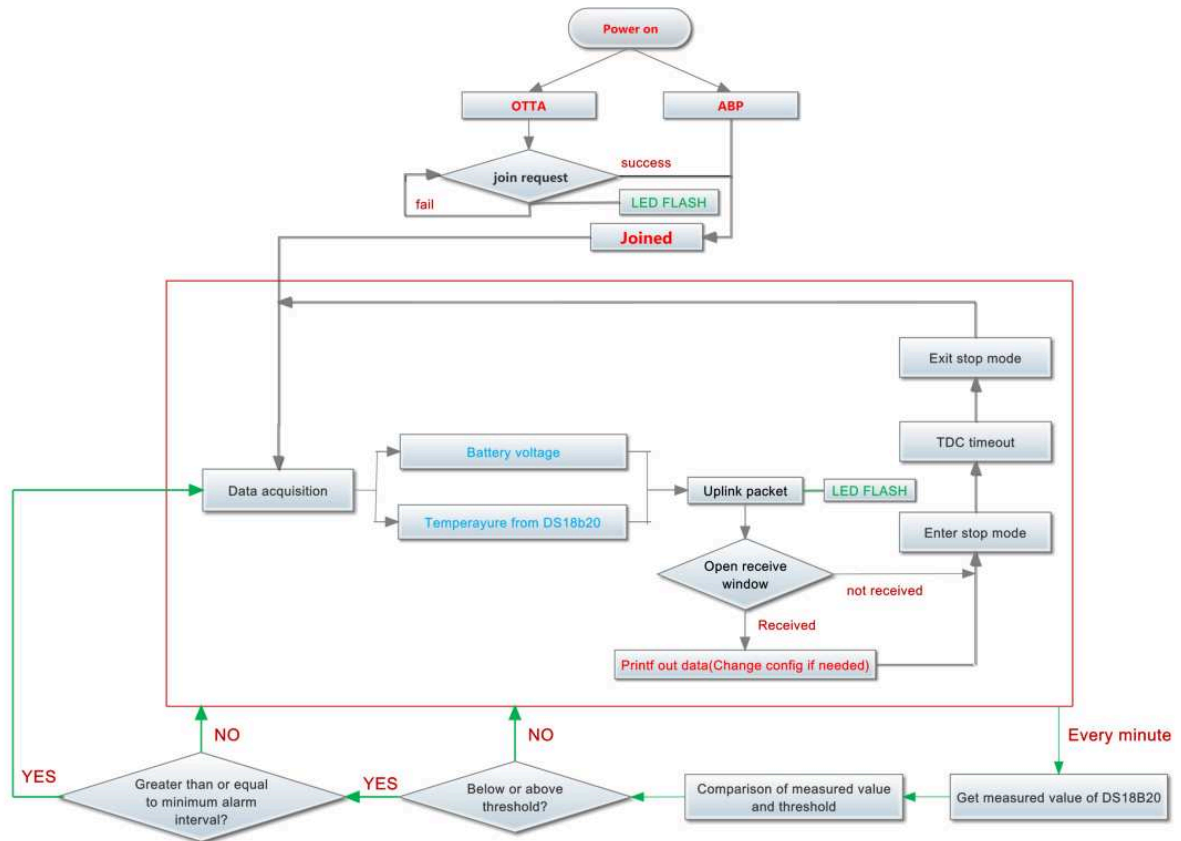

## 2.7 Frequency Plans

The D2x-LB/LS uses OTAA mode and below frequency plans by default. Each frequency band use different firmware, user update the firmware to the corresponding band for their country.

<http://wiki.dragino.com/xwiki/bin/view/Main/End%20Device%20Frequency%20Band/>

## 2.8 Firmware Change Log

Firmware download link:

<https://www.dropbox.com/sh/tcpq06yl7rxrgcz/AACpAC7cy-tnGPqn6T6SUDEaa?dl=0>

# 3. Configure D2x-LB/LS

## 3.1 Configure Methods:

D2x-LB/LS supports below configure method:

- AT Command via Bluetooth Connection (**Recommended**): [BLE Configure Instruction](#).
- AT Command via UART Connection : See [Connection](#).
- LoRaWAN Downlink. Instruction for different platforms: See [IoT LoRaWAN Server](#) section.

## 3.2 General Commands

These commands are to configure:

- General system settings like: uplink interval.
- LoRaWAN protocol & radio related command.

They are same for all Dragino Devices which support DLWS-005 LoRaWAN Stack. These commands can be found on the wiki:

<http://wiki.dragino.com/xwiki/bin/view/Main/End%20Device%20AT%20Commands%20and%20Downlink%20Command/>

### 3.3 Commands special design for D2x-LB/LS

These commands only valid for D2x-LB/LS, as below:

#### 3.3.1 Set Transmit Interval Time

Feature: Change LoRaWAN End Node Transmit Interval.

**AT Command: AT+TDC**

Command Example	Function	Response
AT+TDC=?	Show current transmit Interval	30000 OK the interval is 30000ms = 30s
AT+TDC=60000	Set Transmit Interval	OK Set transmit interval to 60000ms = 60 seconds

**Downlink Command: 0x01**

Format: Command Code (0x01) followed by 3 bytes time value.

If the downlink payload=0100003C, it means set the END Node's Transmit Interval to 0x00003C=60(S), while type code is 01.

- Example 1: Downlink Payload: 0100001E // Set Transmit Interval (TDC) = 30 seconds
- Example 2: Downlink Payload: 0100003C // Set Transmit Interval (TDC) = 60 seconds

#### 3.3.2 Get Device Status

Send a LoRaWAN downlink to ask device send Alarm settings.

- **Downlink Payload:** 0x26 01

Sensor will upload Device Status via FPORT=5. See payload section for detail.

#### 3.3.3 Set Alarm Thredhold

**1. Set for All Probes:**

**AT+18ALARM=min,max**

- When min=0, and max≠0, Alarm trigger when higher than max
- When min≠0, and max=0, Alarm trigger when lower than min
- When min≠0 and max≠0, Alarm trigger when higher than max or lower than min

**Example:**

AT+18ALARM=-10,30 // Alarm when < -10 or higher than 30.

- **Downlink Payload:**

0x(0B F6 1E) // Same as AT+18ALARM=-10,30

(note: 0x1E= 30, 0xF6 means: 0xF6-0x100 = -10)

## 2. Set for Separate Probe:

**AT+18ALARM=min,max,index**

Index:

- 1: Temperature\_Red
- 2: Temperature\_White
- 3: Temperature\_Black

### Example:

AT+18ALARM=-10,30,1 // Alarm when temperature\_red < -10 or higher than 30.

- **Downlink Payload:**

0x(0B F6 1E 01) // Same as AT+18ALARM=-10,30,1

(note: 0x1E= 30, 0xF6 means: 0xF6-0x100 = -10)

### 3.3.4 Set Alarm Interval

The shortest time of two Alarm packet. (unit: min)

- **AT Command:**

AT+ATDC=30 // The shortest interval of two Alarm packets is 30 minutes, Means is there is an alarm packet uplink, there won't be another one in the next 30 minutes.

- **Downlink Payload:**

0x(0D 00 1E) ---> Set AT+ATDC=0x 00 1E = 30 minutes

### 3.3.5 Get Alarm settings

Send a LoRaWAN downlink to ask device send Alarm settings.

- **Downlink Payload:** 0x0E 01

### Example:

Applications > engineer-lin > Devices > Isn50 > Data

**APPLICATION DATA** || pause 🗑 clear

Filters: uplink downlink activation ack error

time	counter	port	payload	ADC_CH0V: 0.088	BatV: 3.313	Digital_IStatus: "L"	Door_status:
15:27:11	2	2	payload: 0C F1 01 0E 00 58 00 FF FF FF FF				
15:26:47	1	2	payload: 0CEC 01 0E 00 1E 7C 00 00 00 00	BatV: 3.308	SHTEMPMAX: 0	SHTEMPMIN: 0	SHTHUMMAX: 0
15:26:51	1	confirmed ack	app id: engineer-lin				
15:26:47	1	confirmed	payload: 0E 01				
15:26:43	0	2	payload: 0C E8 01 0E 00 E6 00 FF FF FF FF	ADC_CH0V: 0.23	BatV: 3.304	Digital_IStatus: "L"	Door_status:
15:26:39			dev addr: 26 01 45 E4 app eui: F1 B8 FBD9 FC 6B F1 4D dev eui: 00 35 86 EC 8DB9 9EDB				

**Alarm status**

Annotations: **DS18B20 minimum of alarm value** (pointing to 001E) and **DS18B20 maximum of alarm value** (pointing to 7C).

**Explain:**

- Alarm & MOD bit is 0x7C, 0x7C >> 2 = 0x31: Means this message is the Alarm settings message.

**3.3.6 Set Interrupt Mode**

Feature, Set Interrupt mode for PA8 of pin.

When AT+INTMOD=0 is set, PA8 is used as a digital input port.

**AT Command: AT+INTMOD**

Command Example	Function	Response
AT+INTMOD=?	Show current interrupt mode	0 OK the mode is 0 =Disable Interrupt
AT+INTMOD=2	Set Transmit Interval 0. (Disable Interrupt), 1. (Trigger by rising and falling edge) 2. (Trigger by falling edge) 3. (Trigger by rising edge)	OK

**Downlink Command: 0x06**

Format: Command Code (0x06) followed by 3 bytes.

This means that the interrupt mode of the end node is set to 0x000003=3 (rising edge trigger), and the type code is 06.

- Example 1: Downlink Payload: 06000000 // Turn off interrupt mode
- Example 2: Downlink Payload: 06000003 // Set the interrupt mode to rising edge trigger

**3.3.7 Set Power Output Duration**

Control the output duration 5V . Before each sampling, device will

1. first enable the power output to external sensor,
2. keep it on as per duration, read sensor value and construct uplink payload
3. final, close the power output.

**AT Command: AT+5VT**

Command Example	Function	Response
AT+5VT=?	Show 5V open time.	0 (default) OK
AT+5VT=1000	Close after a delay of 1000 milliseconds.	OK

#### Downlink Command: 0x07

Format: Command Code (0x07) followed by 2 bytes.

The first and second bytes are the time to turn on.

- Example 1: Downlink Payload: 070000 ---> AT+5VT=0
- Example 2: Downlink Payload: 0701F4 ---> AT+5VT=500

### 3.3.8 Multiple VDC collections in one uplink(Since firmware version 1.3.2)

Added AT+STDC command to collect the voltage of **VDC\_INPUT** multiple times and upload it at one time.

#### AT Command: AT +STDC

AT+STDC=aa,bb,bb

**aa:**

**0:** means disable this function and use TDC to send packets.

**1:** means enable this function, use the method of multiple acquisitions to send packets.

**bb:** Each collection interval (s), the value is 1~65535

**cc:** the number of collection times, the value is 1~120

Command Example	Function	Response
AT+STDC=?	Get the mode of multiple acquisitions and one uplink.	1,10,18 OK
AT+STDC=1,10,18	Set the mode of multiple acquisitions and one uplink, collect once every 10 seconds, and report after 18 times.	Attention:Take effect after ATZ OK
AT+STDC=0, 0,0	Use the TDC interval to send packets.(default)	Attention:Take effect after ATZ OK

#### Downlink Command: 0xAE

Format: Command Code (0x08) followed by 5 bytes.

- Example 1: Downlink Payload: AE 01 02 58 12 ---> AT+STDC=1,600,18

## 4. Battery & Power Consumption

D2x-LB use ER26500 + SPC1520 battery pack and D2x-LS use 3000mAh Recharable Battery with Solar Panel. See below link for detail information about the battery info and how to replace.

[Battery Info & Power Consumption Analyze](#) .

## 5. OTA firmware update

User can change firmware D2x-LB/LS to:

- Change Frequency band/ region.
- Update with new features.
- Fix bugs.



Firmware and changelog can be downloaded from : [Firmware download link](#)

Methods to Update Firmware:

- (Recommended way) OTA firmware update via wireless : <http://wiki.dragino.com/xwiki/bin/view/Main/Firmware%20OTA%20Update%20for%20Sensors/>
- Update through UART TTL interface : [Instruction](#).

## 6. FAQ

## 7. Order Info

**Part Number:** [D20-LB-XX](#) or [D20-LS-XX](#) / [D20S-LB-xx](#) or [D20S-LS-XX](#)(designed for used in Soil or Road) / [D22-LB-XX](#) or [D22-LS-XX](#) / [D23-LB-XX](#) or [D20-LS-XX](#)

**XX:** The default frequency band

- **AS923:** LoRaWAN AS923 band
- **AU915:** LoRaWAN AU915 band
- **EU433:** LoRaWAN EU433 band
- **EU868:** LoRaWAN EU868 band
- **KR920:** LoRaWAN KR920 band
- **US915:** LoRaWAN US915 band
- **IN865:** LoRaWAN IN865 band
- **CN470:** LoRaWAN CN470 band

## 8. Packing Info

**Package Includes:**

- D2x-LB or D2x-LS LoRaWAN Temperature Sensor

**Dimension and weight:**

- Device Size: cm
- Device Weight: g
- Package Size / pcs : cm
- Weight / pcs : g

## 9. Support

- Support is provided Monday to Friday, from 09:00 to 18:00 GMT+8. Due to different timezones we cannot offer live support. However, your questions will be answered as soon as possible in the before-mentioned schedule.
- Provide as much information as possible regarding your enquiry (product models, accurately describe your problem and steps to replicate it etc) and send a mail to [Support@dragino.cc](mailto:Support@dragino.cc).